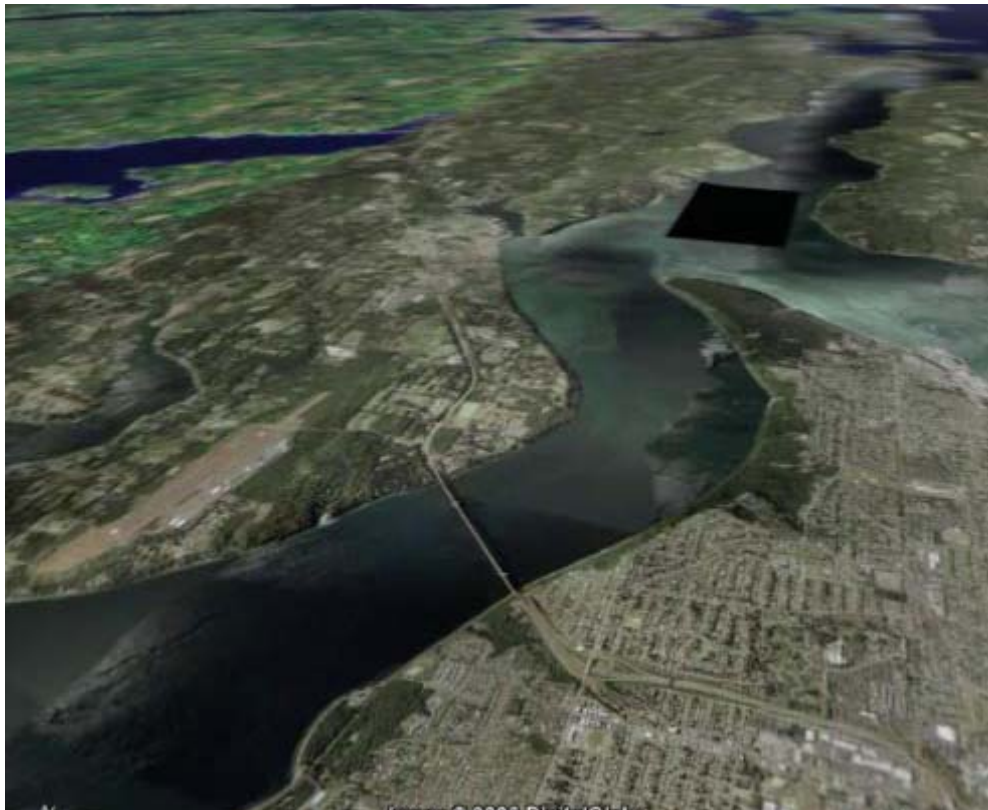




System Level Design, Performance, Cost and Economic Assessment – Tacoma Narrows Washington Tidal In-Stream Power Plant



Project: EPRI North American Tidal In Stream Power Feasibility Demonstration Project
Phase: 1 – Project Definition Study
Report: EPRI – TP – 006 WA
Author: Brian Polagye and Mirko Previsic
Contributors: George Hagerman and Roger Bedard
Date: June 10, 2006

DISCLAIMER OF WARRANTIES AND LIMITATION OF LIABILITIES

This document was prepared by the organizations named below as an account of work sponsored or cosponsored by the Electric Power Research Institute Inc. (EPRI). Neither EPRI, any member of EPRI, any cosponsor, the organization (s) below, nor any person acting on behalf of any of them.

(A) Makes any warranty or representation whatsoever, express or implied, (I) with respect to the use of any information, apparatus, method, process or similar item disclosed in this document, including merchantability and fitness for a particular purpose, or (II) that such use does not infringe on or interfere with privately owned rights, including any party's intellectual property, or (III) that this document is suitable to any particular user's circumstance; or

(B) Assumes responsibility for any damages or other liability whatsoever (including any consequential damages, even if EPRI or any EPRI representative has been advised of the possibility of such damages) resulting for your selection or use of this document or any other information, apparatus, method, process or similar item disclosed in this document.

Organization(s) that prepared this document

Electricity Innovation Institute

Global Energy Partners LLC

Virginia Polytechnic Institute and State University

Mirko Previsic Consulting

Brian Polagye¹ Consulting

¹ PhD Student, Department of Mechanical Engineering, University of Washington

Table of Contents

1.	Introduction and Summary	6
2.	Site Selection	11
2.1.	Tidal Energy Resource	13
2.2.	Grid Interconnection Options	18
2.3.	Nearby Port Facilities	19
2.4.	Bathymetry	20
2.5.	Seabed Composition	21
2.6.	Navigational Clearance	24
2.7.	Other Site Specific Considerations	24
3.	Marine Current Turbines	26
3.1.	Device Performance	27
3.2.	Device Specification	29
3.3.	MCT Device Evolution	30
3.4.	Monopile Foundations	33
3.5.	Pile Installation	34
3.6.	Operational and Maintenance Activities	38
4.	Electrical Interconnection	41
4.1.	Subsea Cabling	42
4.2.	Onshore Cabling and Grid Interconnection	44
5.	System Design – Pilot Plant	45
6.	System Design - Commercial Plant	49
6.1.	Array Layout	49
6.2.	Electrical Interconnection	52
6.3.	Array Performance	54
6.4.	Site Specific Issues	58
7.	Cost Assessment – Pilot Plant	60
8.	Cost Assessment – Commercial Plant	61
9.	Cost of Electricity Assessments	65
10.	Sensitivity Studies	71
10.1.	Array Size	71
10.2.	Array Availability	73
10.3.	Current Velocity	73
10.4.	Design Velocity	75
10.5.	Financial Assumptions	75

- 11. Conclusions 77
 - 11.1. Pilot In-Stream Tidal Power Plant 77
 - 11.2. Techno-economic Challenges 78
 - 11.3. General Conclusions 79
 - 11.4. Recommendations 82

- 12. References 85

- 13. Appendix 87
 - 13.1. Validity of Pt. Evans Velocity Predictions for Commercial Array 87
 - 13.2. Irrelevance of Flow Decay Concerns 88
 - 13.3. Hub-height Velocity Approximation 89
 - 13.4. Utility Generator Cost of Electricity Worksheet 93
 - 13.5. Non Utility Generator Internal Rate of Return Worksheet 100
 - 13.6. Municipal Utility Generator Cost of Electricity Worksheet 105

Table of Figures

Figure 1 – Tacoma Narrows [5]	11
Figure 2 – Tacoma Narrows NOAA Current Stations [5,7].....	14
Figure 3 – Tidal Cycle Velocity Variation at Pt. Evans (February 1 st -14 th , 2005)	15
Figure 4 –Tidal Current Histogram for Pt. Evans	15
Figure 5 – Depth Profile of Tacoma Narrows in vicinity of Pt. Evans	16
Figure 6 – Daily Channel Power Variation at Pt. Evans (February 9 th , 2005).....	17
Figure 7 – Tidal Cycle Channel Power Variation at Pt. Evans (February 1 st -14 th , 2005).....	18
Figure 8 – Monthly Average Channel Power at Pt. Evans (2005).....	18
Figure 9 – Interconnection Infrastructure near Pt. Evans [5].....	19
Figure 10 – Aerial Photograph of Port of Tacoma [5]	20
Figure 11 – Tacoma Narrows Bathymetry	21
Figure 12 – Tacoma Narrows Seabed Composition [9].....	22
Figure 13 – Seabed Composition, Tacoma Narrows Bridge (1939) [13]	23
Figure 14 – MCT SeaGen (courtesy of MCT)	26
Figure 15 – Comparison of Flow and Electric Power at Pt. Evans	29
Figure 16 – Daily Variation of Flow and Electric Power at Pt. Evans (February 9 th , 2005)	29
Figure 17 – MCT SeaFlow Test Unit (courtesy of MCT).....	31
Figure 18 - Conceptual MCT deep water configuration (courtesy of MCT)	32
Figure 19 - Simulation of pile-soil interaction subject to lateral load [23].....	33
Figure 20 - Pile Weight as a function of design velocity for different sediment types.....	34
Figure 21 – Pile Installed in Bedrock (courtesy of Seacore Ltd.).....	35
Figure 22 - Manson Construction 600 ton Derrick Barge WOTAN operating offshore (courtesy of Manson Construction).....	36
Figure 23 - Typical Rigid Inflatable Boat (RIB).....	39
Figure 24 – Generalized interconnection for turbine array	41
Figure 25 – Armored submarine cables	43
Figure 26 – Pt. Evans Pilot Plant Layout	46
Figure 27 - Conceptual Electrical Design for a single TISEC Unit.....	47
Figure 28 – Pilot Plant Interconnection.....	48
Figure 29 – Pt. Evans Commercial Array Layout.....	49
Figure 30 – Turbine Size and Spacing	51
Figure 31 – Pile Installation Depth Distribution	52
Figure 32 – Commercial Plant Interconnection	54
Figure 33 – Daily Array Power Output (February 9 th , 2005).....	55
Figure 34 – Tidal Cycle Array Power Output (February 1 st -14 th , 2005).....	56
Figure 35 – Daily Average Array Power (2005).....	56
Figure 36 – Monthly Average Array Power Output (2005).....	57
Figure 37 – MCT SeaFlow (courtesy of MCT).....	59
Figure 38 – Sensitivity of COE to number of turbines installed.....	71
Figure 39 – Sensitivity of Capital Cost elements to number of installed turbines.....	72
Figure 40 – Sensitivity of annual O&M cost to number of installed turbines	72
Figure 41 – Sensitivity of COE to array availability.....	73
Figure 42 – Sensitivity of COE to average velocity.....	74
Figure 43 – Sensitivity of COE to average power flux	74

Figure 44 – Sensitivity of COE to design speed	75
Figure 45 – Sensitivity of COE to debt financing rate	76
Figure 46 – Sensitivity of COE to production credits	76
Figure 47 – PRISM Model Predictions for Tacoma Narrows	87
Figure 48 – Representative Numerical Integration	91

List of Tables

Table 1 - Relevant Site Design Parameters.....	13
Table 2 – Tacoma Narrows NOAA Current Stations Predicted Velocity and Power Flux ..	14
Table 3 – Channel and Extractable Power at Pt. Evans	17
Table 4 – Device Performance at Pt. Evans	28
Table 5 – SeaGen Device Specification for Target Site.....	30
Table 6 – Pilot Grid Interconnection.....	48
Table 7 – Pt. Evans Transect MVA Ratings	52
Table 8 – Pt. Evans Commercial Array Grid Interconnection	54
Table 9 – Pt. Evans Array Performance	55
Table 10 – Pilot Plant Cost Breakdown	60
Table 11 - Commercial Plant Cost Breakdown.....	63
Table 12 - COE for Alternative Energy Technologies: 2010.....	68
Table 13 – Approximation Variance as Function of Hub Height	91

1. Introduction and Summary

This document describes the results of a system level design, performance and cost study for both a feasibility demonstration pilot plant and a commercial size in-stream tidal power plant installed in Tacoma Narrows. For purposes of this design study, the Washington (WA) stakeholders selected the Marine Current Turbine (MCT) tidal in-stream energy conversion (TISEC) device for deployment at Point Evans. The study was carried out using the methodology and standards established in the Design Methodology Report [4], the Power Production Performance Methodology Report [1] and the Cost Estimate and Economics Assessment Methodology Report [2].

This study evaluates a MCT SeaGen device consisting of two horizontal-axis rotors and power trains (gearbox, generator) attached to a supporting monopile by a cross-arm. The monopile is surface piercing and includes an integrated lifting mechanism to pull the rotors and power trains out of the water without the intervention of specialized marine craft. The pilot would cost \$4.2M to build and produced an estimated 2010 MWh per year (716 kW rated electric power). This cost reflects only the capital needed to purchase a SeaGen unit, install it on site, and connect it to the grid. Therefore, it represents the installed capital cost required to evaluate and test a SeaGen TISEC system, but does not include detailed design, permitting and construction financing, yearly O&M or test and evaluation costs.

A commercial scale tidal power plant at the same location was also evaluated to establish a base case from which economic comparisons to other renewable and non renewable energy systems could be made. Unlike the pilot scale turbine, commercial turbines will not be surface piercing. This serves to reduce the visual impact of the array and avoid multiple-use conflicts with deep draft container traffic passing through the Narrows en route to the port of Olympia. The cost assessment for a commercial array is predicated on the assumption that costs for a fully submerged MCT device will be in line with the surface piercing SeaGen. This fully submerged variant would incorporate the same power train and foundation as the SeaGen on a different support structure. At this point, that support

structure and lifting mechanism are conceptual and create significant technical and economic uncertainty that must be eliminated prior to the installation of a commercial array. For the proposed commercial plant of sixty-four dual-rotor turbines, the yearly electrical energy produced and delivered to bus bar is estimated to be 120,000 MWh/year. These turbines will, on average, extract 16MW of kinetic power from the tidal stream – 15% of the total kinetic energy in the flow at Point Evans. Turbines could be arranged in five rows of twelve to thirteen devices. The elements of cost and economics (in 2005\$) are:

- Total Plant Investment = \$103 million
- Annual O&M Cost = \$3.8 million
- Utility Generator (UG) Levelized Cost of Electricity (COE)² = 9.0 (Real) – 10.6 (Nominal) cents/kWh with renewable energy incentives equal to those that the government provides for renewable wind energy technology
- Non Utility Generator (NUG) Levelized Cost of Electricity (IRR) = N/A (low avoided cost of electricity in WA)
- Municipal Generator (MG) Levelized Cost of Electricity (COE) = 7.2 (Real) – 8.4 (Nominal) cents/kWh with renewable energy incentives equal to those that the government provides for renewable wind energy technology

While not competitive with fossil generation in the near term, this is lower than the cost of energy for wind or solar installations possible in the Puget Sound area and, as such, represents a low cost local renewable power option for the city of Tacoma.

Tacoma Narrows has the potential of being a good location for siting an in-stream tidal power plant. Strong currents occur four times each day, embodying, on average, over 100MW of kinetic energy. Both sides of Tacoma Narrows have significant electrical infrastructure and power take-off cables may be readily brought ashore at Pt. Evans using existing utility easements. Tacoma Narrows is in close proximity to the Port of Tacoma – a major port facility which could serve as a base of operations for both installation and maintenance.

A pilot demonstration tidal plant in the Tacoma Narrows is recommended to help address the issues such as:

- Reliability and availability
- Most cost effective type of technology and optimum size for individual turbines
- Uncertainty in project costs, particularly installation and O&M costs
- Dispatcher ability to make use of a predictable, though varying resource
- Regulatory willingness to permit TISEC installations
- Political and public acceptance

In-stream tidal energy is a potential important energy source and should be evaluated for addition to Tacoma's energy supply portfolio. A balanced and diversified portfolio of energy supply options is the foundation of a reliable and robust electric grid. TISEC offers an opportunity for Tacoma to expand its supply portfolio with a resource that is:

- Local – providing long-term energy security and keeping development dollars in the region
- Sustainable and green-house gas emission free
- Cost competitive compared to other options for expanding and balancing the region's supply portfolio

Except for a few large tidal energy resource sites, such as Minas Passage, TISEC is in the grey zone between central and distributed power applications. Typical distributed generation (DG) motivations are:

- Delay transmission and distribution (T&D) infrastructure upgrade
- Provide voltage stability
- Displace diesel fuel in off-grid applications
- Provide guaranteed power

² For the 45.7 MW, 20 year plant life, 10 years of PTC at 0.18 cents/kWh for a taxable entity, a REPI credit at 0.015 cents/kWh for a non taxable MG, and other assumptions documented in [2].

In order to promote development of TISEC, EPRI recommends that stakeholders build collaboration within Washington and with other State/Federal Government agencies by forming a state electricity stakeholder group and joining TISEC Working Group to be formed by EPRI. Additionally, EPRI encourages the stakeholders to support related R&D activities at a state and federal level and at universities in the region. This would include:

- Implement a national ocean tidal energy program at DOE
- Operate a national offshore ocean tidal energy test facility
- Promote development of industry standards
- Continue membership in the IEA Ocean Energy Program
- Clarify and streamline federal permitting processes
- Study provisions for tax incentives and subsidies
- Ensure that the public receives a fair return from the use of ocean tidal energy resources
- Ensure that development rights in state waters are allocated through a fair and transparent process that takes into account state, local, and public concerns.

As Tacoma Power has already applied for and received a preliminary permit from FERC for a pilot feasibility demonstration plant at Pt. Evans in Tacoma Narrows, we recommend that Tacoma Power progress forward with other Phase II (Detailed Design and Permitting Project) tasks including:

- Velocity profiling survey (ADCP with CFD)
- High resolution bottom bathymetry survey
- Geotechnical survey
- Detailed engineering design using above data
- Environmental impact report
- Public outreach
- Implementation planning for Phase III (Construction)
- Financing/incentive requirements study for Phase III and IV (Operation)

In order to facilitate planning for a commercial plant, we recommend that Tacoma Power develop and support intellectual capital required for effective deployment of large TISEC arrays. This would include activities such as:

- Modeling effect of turbines on current flows throughout Puget Sound. This would serve to justify the expected low impact of TISEC. Additionally, this model could be used to understand the impact of further development of tidal energy upstream of Tacoma Narrows (e.g. Admiralty Inlet).
- Understanding array spacing limitations. In order to minimize the array footprint and take advantage of the most energetic water it will be imperative to cluster turbines as closely as possible without allowing the wake of one turbine to degrade the performance of another.

This intellectual capital will take some time to develop and may be strongly site dependent. Each of the above points represents a significant unknown in the deployment of commercial-scale tidal in-stream energy.

2. Site Selection

The Washington stakeholders selected Tacoma Narrows for an assessment of in-stream tidal power. Fabrication, assembly, and operation and maintenance would be performed out of the Port of Tacoma. Grid interconnection would be on the Gig Harbor (western) side of the Narrows where Tacoma Power has 115kV transmission lines. Figure 1 shows an aerial schematic of Tacoma Narrows.



Figure 1 – Tacoma Narrows [5]

Tacoma Narrows is located in Puget Sound, approximately eight miles west of downtown Tacoma, and separates the main basin from the south basin. While much of the Puget Sound to the north and south of the Narrows is quite deep and wide (e.g. 230m deep and 6500m wide between Vashon Island and the mainland), Tacoma Narrows is relatively shallow and narrow. As a result, the twice-daily tidal exchange generates high velocities as water moves through the constriction.

Site selection is determined by the following primary considerations:

- Strong tidal energy resource
- Low-cost interconnection
- Close proximity to major port

The Pt. Evans site satisfies all these criteria. Tidal currents at Pt. Evans are the strongest reported in the Narrows – 1.2 m/s average speed. This translates to a depth averaged power flux of 1.7 kW/m² using the methodology described in [1]. The channel at Pt. Evans has a substantial average cross-section (63,000 m²), yielding an average flow power of 106 MW. Tacoma Power has high voltage electrical transmission lines (115 kV) crossing at Pt. Evans which could accommodate the power generated by a commercial array. Tacoma Narrows is in close proximity to the Port of Tacoma, a major port annually handling over \$29B in trade goods [6]. In short – the site is optimal for TISEC device deployment.

In addition to issues driving the general siting decision, other factors are important to take into account in the design process:

- Bathymetry: relatively flat seafloor preferred
- Seabed composition: bearing capacity and type will determine foundation design
- Navigational clearance: turbines may need to share waterway with shipping traffic
- Site specific issues: turbine interaction with marine life, etc.

These issues, as well as those discussed above are considered in more detail in the following sections. Site parameters are summarized in Table 1.

Table 1 - Relevant Site Design Parameters

Site	
Channel Width	1,490 m
Average Depth (from MLLW)	42 m
Deepest Point	68 m
Maximum Tidal Range	5 m
Seabed Type	Dense sand and gravel
Tidal Energy Statistics	
Depth Averaged Power Density	1.7 kW/m ²
Average Power Available	106 MW
Average Power Extractable (15%)	16 MW
# Homes equivalent (1.3 kW/home)	11,000
Peak Velocity at Site	3.9 m/s
Interconnection	
Pilot Plant	Connection to existing distribution line at 12.47kV
Commercial Plant	Connection to new 115kV substation at 33kV
Nearest Port	Port of Tacoma (20 km)

2.1. Tidal Energy Resource

When siting a commercial TISEC system, the primary consideration is the magnitude of the resource. This is a function of the strength of the currents and cross-sectional area of the channel.

Since power varies with the cube of velocity, even small variations in velocity have a big impact on power. The power flux – or power per unit area – of a tidal current is given by $P = \frac{1}{2} \rho U^3$, where P is the power flux (kW/m²), ρ is the density of seawater (1024 kg/m³), and U is the current velocity (m/s).

The methodology for calculating currents (m/s) and power flux (kW/m²) in Tacoma Narrows is described in [1]. Based on NOAA tidal current stations (2005 predictions), the power flux at Pt. Evans is the strongest in Tacoma Narrows. This is not to say that stronger currents might not exist elsewhere in the channel – only that identification of these currents will require additional measurements and modeling. The approximate locations of the tidal current stations are shown in Figure 2 and the strength of the currents at each station is given in Table 2. The power flux at Pt. Evans is highest.

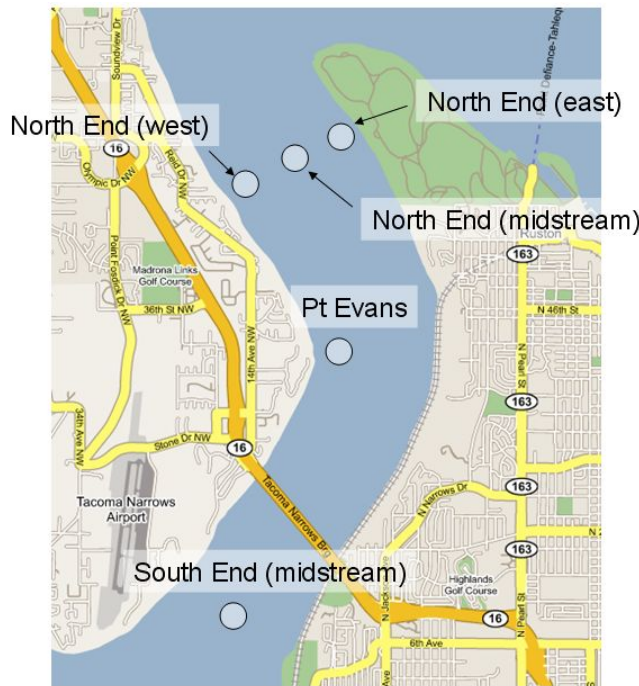


Figure 2 – Tacoma Narrows NOAA Current Stations [5,7]

Table 2 – Tacoma Narrows NOAA Current Stations Predicted Velocity and Power Flux

Station	Depth Averaged Velocity (m/s)	Depth Averaged Power Flux (kW/m ²)
North End (east)	1.08	1.47
North End (midstream)	0.90	0.86
North End (west)	0.60	0.40
Pt. Evans	1.12	1.70
South End (midstream)	1.03	1.33

Variations in surface currents over a representative tidal cycle are shown in Figure 3. Tides in Puget Sound exhibit a high degree of diurnality – a strong tide is often followed by a much weaker one. This diurnality is not unique to Tacoma Narrows and is, in fact, present at other current stations throughout Puget Sound, including Admiralty Inlet at the northern end. At Pt. Evans, the flood tide is stronger than the ebb (average maximum flood = 2.2 m/s, average maximum ebb = 1.7 m/s). The tides are effectively bi-directional, with ebb and flood offset by 178° (180° for perfectly bi-directional) [7].

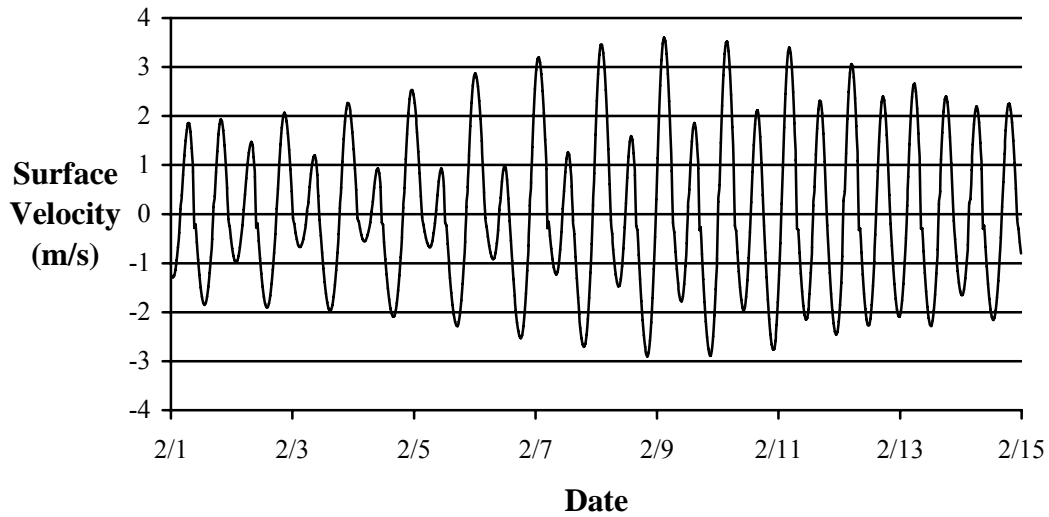


Figure 3 – Tidal Cycle Velocity Variation at Pt. Evans (February 1st-14th, 2005)

These data are most conveniently represented by a histogram of velocities and frequencies. A histogram for the tidal currents at Pt. Evans is given in Figure 4.

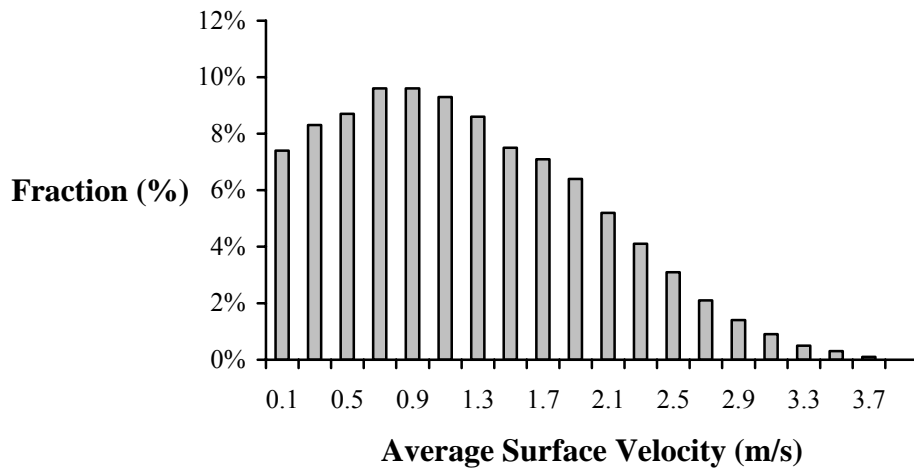


Figure 4 –Tidal Current Histogram for Pt. Evans

Second only to power flux in the viability of a tidal energy site is the channel mass flow rate – a function of the velocity and cross-sectional area. Total power is equal to power flux (kW/m^2) multiplied by channel cross-section (m^2). As a result, tiny channels with high power flux are of little use for commercial tidal power generation since the overall tidal resource is quite small. For example, Deception Pass in northern Puget Sound experiences

high velocities, but has a very small cross-sectional area and, therefore, could not support a commercial TISEC array.

At Pt. Evans, Tacoma Narrows is approximately 1500m wide. Depth considerations limit large-scale deployment of full-size turbines to the deeper center and east side of the channel. Figure 5 shows a depth profile for Tacoma Narrows in the vicinity of Pt. Evans. The figure is as Tacoma Narrows would appear to an observer standing on the seabed looking north. Depths are referenced to MLLW. Except on the far eastern shore, depth changes relatively gradually across the proposed turbine deployment site.

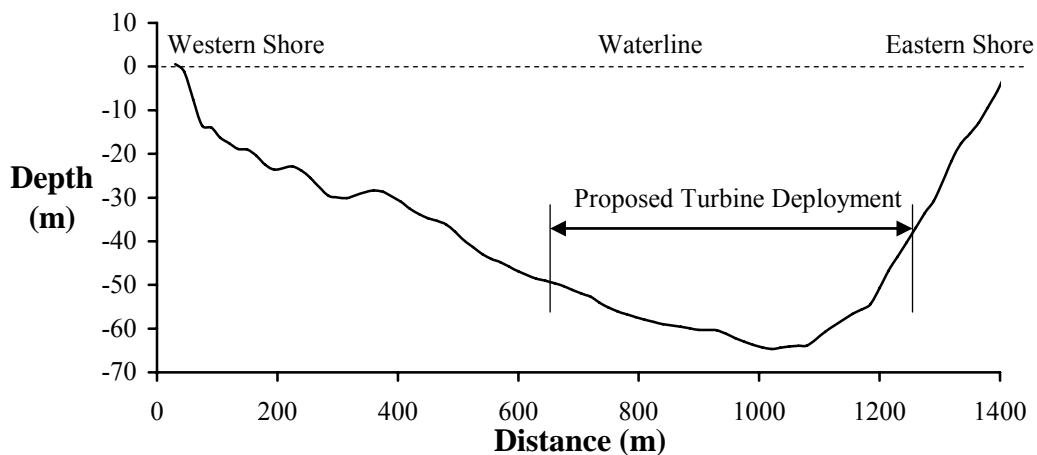


Figure 5 – Depth Profile of Tacoma Narrows in vicinity of Pt. Evans

Due to the tidal range at Tacoma Narrows, the cross-sectional area of Tacoma Narrows varies with time. In the region of interest for turbine deployment, the average cross-sectional area is approximately 63,000 m².

Taken in combination with the power flux discussed in the previous section, channel power for Tacoma Narrows is quite substantial – more than 100 MW on average. Results are summarized in Table 3. In order to avoid any major ecological impact from the operation of this array, no more than 15% of the average channel power may be extracted [1].

Table 3 – Channel and Extractable Power at Pt. Evans

	Depth Averaged Power Flux (kW/m ²)	Cross-sectional Area (m ²)	Channel Power (MW)	Extractable Power (MW)
Annual Average	1.70	63,134	106	16
Maximum	22.74	66,866	1,421	213
Minimum	-	57,849	-	-

Note that average and maximum cross-section and power flux are not exactly coincident, so that average and maximum channel power is not a straight multiplication of power flux and area.

Figure 7 shows predicted channel power variations for a single day (February 9th, 2005). The pattern of diurnality is identical to the diurnality of the tidal currents.

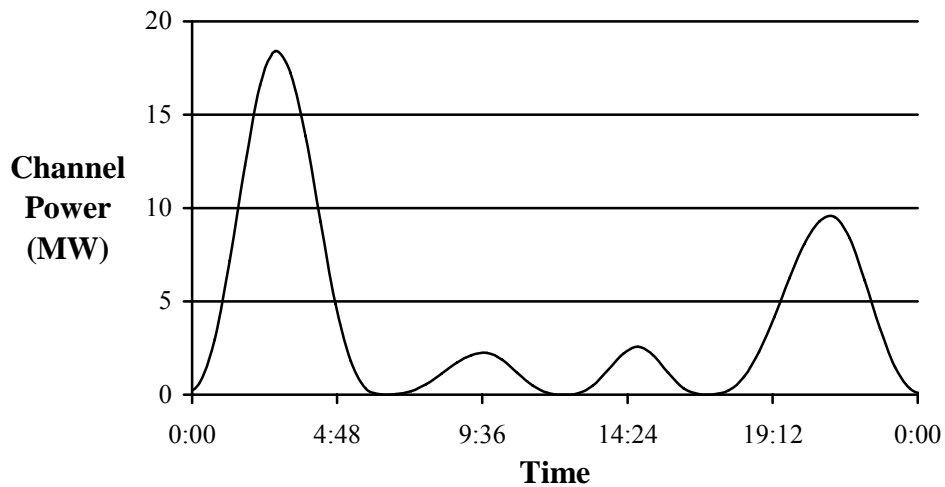
Figure 6 – Daily Channel Power Variation at Pt. Evans (February 9th, 2005)

Figure 7 shows channel power for a 14-day tidal cycle. The variations in channel power due to the tidal cycle are apparent. Of potential concern to TISEC deployment is the diurnality of the tides, which results in relatively long periods of low channel power during which turbines would produce minimal, if any, electric power.

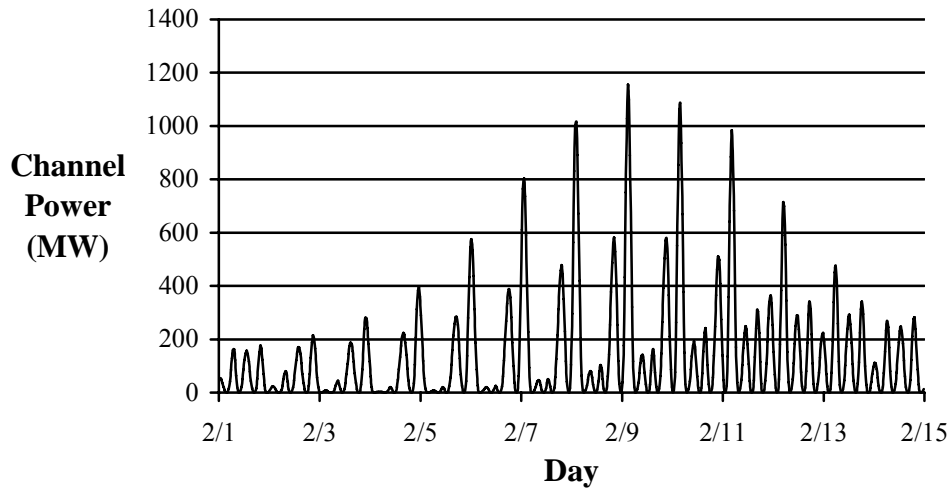


Figure 7 – Tidal Cycle Channel Power Variation at Pt. Evans (February 1st-14th, 2005)

Figure 8 shows monthly average channel power over an entire year. While the average channel power does vary somewhat from month to month, the maximum variation is only 10%.

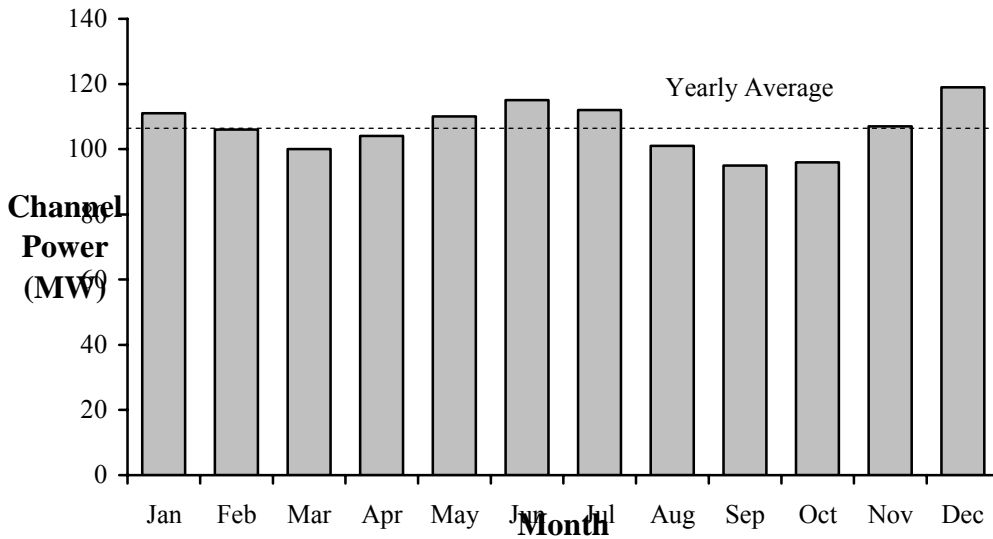


Figure 8 – Monthly Average Channel Power at Pt. Evans (2005)

2.2. Grid Interconnection Options

The power that could be produced from a tidal stream is of little value if large capital outlays would be required to connect it to the electric grid. This barrier has delayed the development of wind power at some sites in the US, since the cost of the transmission lines

to bring the power to market may be on the same order as the cost to construct the wind farm. Fortunately, this is not the case at Tacoma Narrows.

Both Tacoma Power and Peninsula Light Company (Pen Light) have electrical infrastructure in close proximity to the turbine site. Pen Light has 12.47kV distribution lines uphill from Pt. Evans. Tacoma Power has a 115kV line crossing at the site, which connects to a Pen Light owned sub-station located approximately one-half mile away. Transmission infrastructure is show in Figure 9. Note that the 115kV line crossing towers are currently being replaced and an opportunity exists to have pilot and commercial plant interconnection built-in at lower cost than for a green-field project.

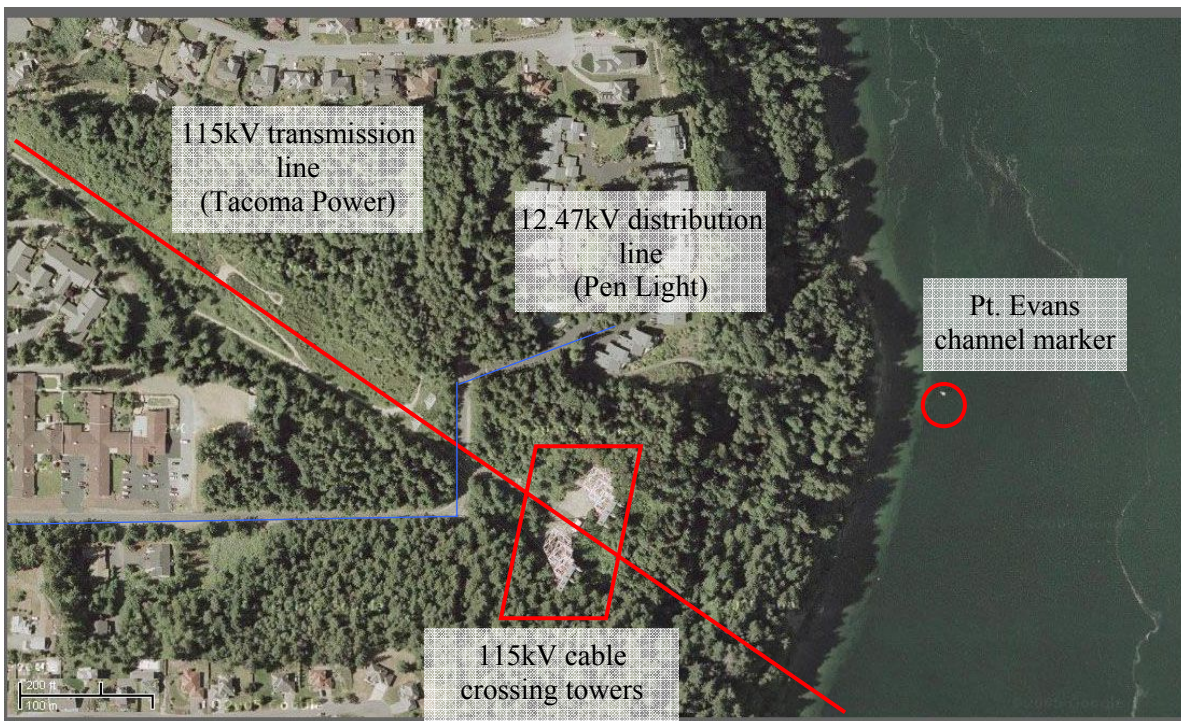


Figure 9 – Interconnection Infrastructure near Pt. Evans [5]

2.3. Nearby Port Facilities

If a turbine is far from a major port, both installation and maintenance costs may be prohibitive due to long mobilization times. Tacoma Narrows is located in close proximity to a number of major port facilities. The Port of Tacoma is approximately 20 km (12.5 miles) from Point Evans. Both Seattle and Olympia could also serve as staging areas for

installation and maintenance, but are more distant – approximately 45 km (28.1 miles). It is possible that Gig Harbor, located even closer to the Narrows than Tacoma but with substantially fewer capabilities, could serve as a staging area for maintenance.



Figure 10 – Aerial Photograph of Port of Tacoma [5]

2.4. Bathymetry

Bathymetry³ is an important determinant in the siting of turbines. In shallow water there may be insufficient surface and seabed clearance to install a turbine. This drives site selection towards deeper water sites. However, installation and maintenance costs increase with water depth. These two competing influences result in a range of depths where it is most practical to deploy a turbine.

10m resolution bathymetric data for Tacoma Narrows were generously provided by NOAA Center for Tsunami Research. These data are presented in Figure 11 – all depths are referenced to mean lower low water (MLLW)⁴. In the left image, which shows the entirety of the Narrows, the white circles mark the locations of the current stations shown in Figure 2. In the right image, the boxed region off Point Evans is the probable location for turbine deployment. Also shown is the approximate position of Tacoma Power’s Right of Way

³ Bathymetry is the oceanographic equivalent of topography.

⁴ Data provided by NOAA Center for Tsunami Research referenced to mean high water (MHW). NOAA tidal range predictions for the Tacoma Narrows Bridge station [8] used to convert from MHW to MLLW.

(ROW) – where power take-off cables from a TISEC array would come ashore and the location of the Point Evans current reference station.

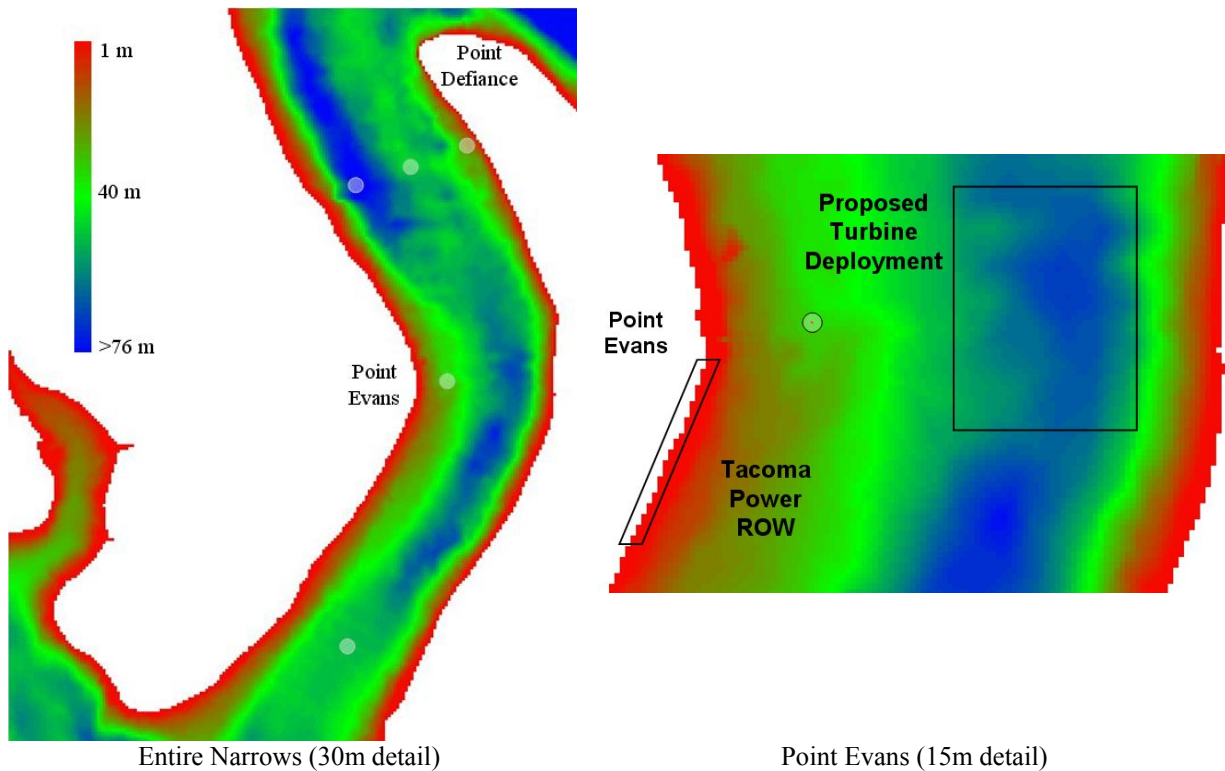
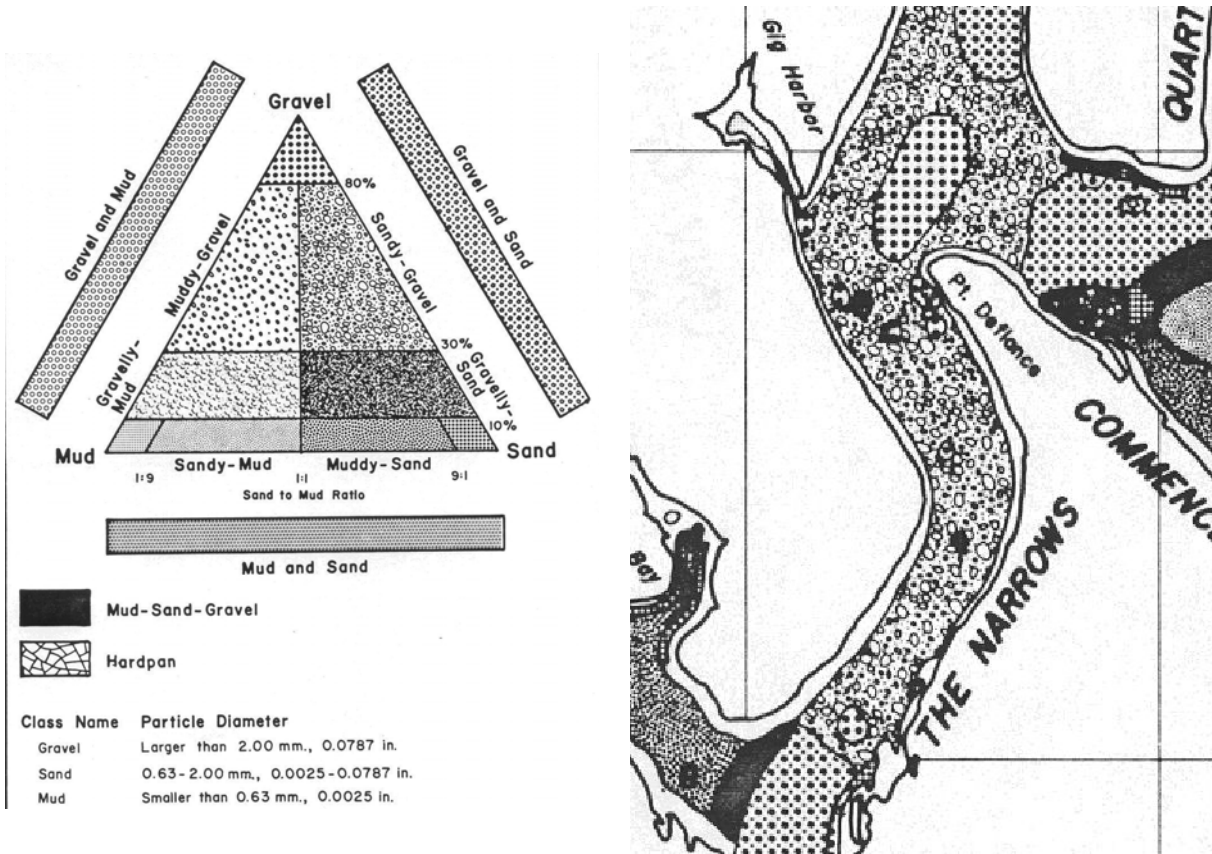


Figure 11 – Tacoma Narrows Bathymetry

Bathymetric data confirms that the Pt. Evans transect is of sufficient depth to support the installation of multiple rows of large diameter TISEC devices.

2.5. Seabed Composition

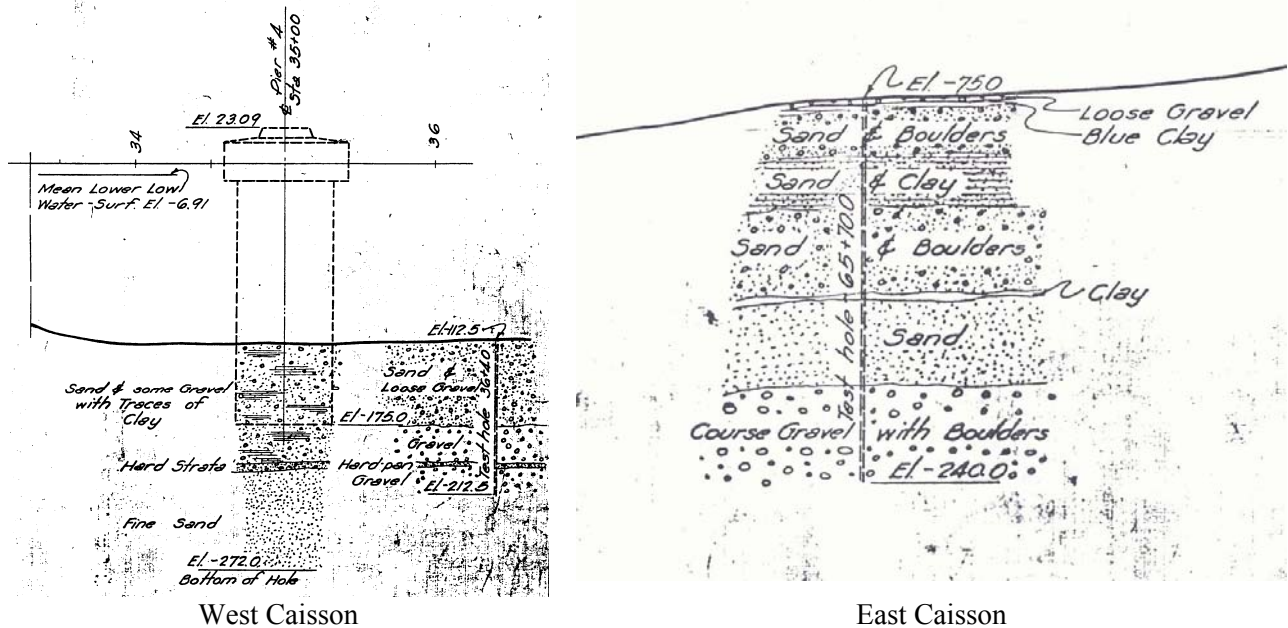
As is the case for most of Tacoma Narrows, the seabed surface in the vicinity of Pt. Evans is generally classified as sandy gravel as (Figure 12) [9]. The triangular legend indicates the relative composition of the seabed between sand, mud, and gravel. For example, based on the texture in the sediment map for Tacoma Narrows, the seabed type is classified as Sandy-Gravel (right side of legend triangle - between 80%/20% and 30%/70% split for gravel/sand).



Legend Map
 Figure 12 – Tacoma Narrows Seabed Composition [9]

Personal communications with individuals familiar with conditions in Tacoma Narrows [10,11] confirm that the seabed around Pt. Evans is heavily scoured with the top layer consisting mostly of gravel and cobbles.

For designing a turbine foundation, the geologic properties of the seabed are of significant interest. While no specific seabed data is readily available at Pt. Evans, the construction of the original and second Tacoma Narrows Bridges has generated a significant body of information on the soil composition in the vicinity of the bridge caissons. Best practices for marine design and construction will necessitate a geologic survey of the potential array location prior to installation, but the data for the bridge site are instructional. Figure 13 shows an artist rendering of the seabed composition in the vicinity of the west caisson for the original Tacoma Narrows Bridge. The seabed is composed of successive layers of consolidated sand, gravel, and clay.



West Caisson East Caisson
Figure 13 – Seabed Composition, Tacoma Narrows Bridge (1939) [13]

Surveys for the new bridge further categorize the seabed composition in layers according to geologic deposition mechanism [14]. For the east caisson of the new bridge, drilling surveys report:

- Quaternary Vashon Recessional Outwash (Qvro): -120' (mudline) to -200'
 - Recessional outwash deposits from glacial retreat
 - Clean to silty sand, gravelly sand, and sandy gravel
 - Cobbles and boulders common
 - Loose to very dense
- Quaternary Pre-Vashon Nonglacial Fluvial (Qpnf): -200' to -280'
 - River and creek deposits
 - Clean to silty sand, gravelly sand, and sandy gravel
 - Scattered organic residue
 - Very dense
- Quaternary Pre-Vashon Glacial Outwash (Qpgo): -280' to end of test
 - Deposited glacial sediments
 - Clean to silty sand, gravelly sand, and sandy gravel
 - Very dense

These primary layers may be interspersed with thin, very hard layers. The Qpnf and Qgpo layers have been consolidated by glacial ice and require considerable force to penetrate. This type of seabed is referred to as ‘hardpan’ with the least desirable aspects of soft sediments and rock – low resistance to shear and high force to penetrate. The thickness of the geologic layers varies somewhat between the east and west caisson test sites, but the general composition is consistent.

2.6. Navigational Clearance

Tacoma Narrows accommodates significant shipping traffic, the largest of which is deep draft container ships bound for the port of Olympia. The maximum reported mean draft for vessels passing through the Narrows is approximately 12m [15,16]. Therefore, for conservatism, a clearance of 15m from LAT (Lowest Astronomical Tide) is assumed. While no shipping channel is defined within the Narrows, by convention, shipping traffic occupies a lane equivalent to the distance between the east and west caissons of the Tacoma Narrows Bridge. For the purposes of this study, the shipping channel is assumed to occupy the center 853m (1200 ft) of Tacoma Narrows.

Outside of the shipping lanes a clearance of 8m from LAT is assumed. This is a highly conservative assumption, as wave action is quite low in Tacoma Narrows and the draft of recreational vessels is well under 8m.

2.7. Other Site Specific Considerations

A number of site specific issues further influence the design of pilot and commercial arrays.

Point Defiance at the northern end of the Narrows and, to a lesser extent, Point Evans induce turbulent eddies in the channel flow. During flood tide, Point Defiance induces a strong corkscrew motion, which results in the overturn of the water column as it enters the Narrows [12]. It has been assumed that this large-scale motion will have substantially dissipated by the time the tidal stream reaches Point Evans. At Point Evans, during ebb and flood tides, a low velocity eddy can be visually observed in the shallow waters north and south, respectively, of the point. This eddy expands into the channel as the flow moves past

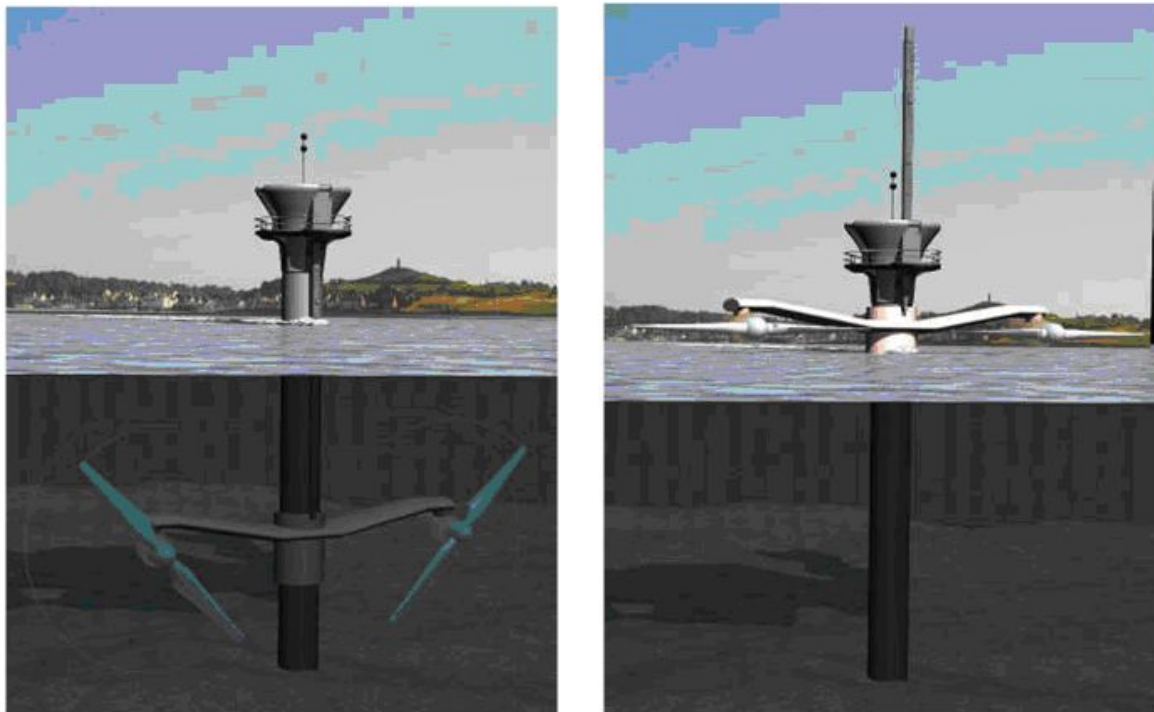
the point and is visually identified by reversing flows and small, standing waves. Turbines should not be installed in eddies as the flow velocity will be much lower than in the undisturbed flow. Furthermore, extreme turbulence is likely to accelerate blade fatigue and reducing operating lifetime.

Tacoma Narrows is a biologically active region. Two types of kelp grow along the shoreline of Tacoma Narrows – floating and understory. As its name suggest, floating kelp is positively buoyant and floats on the surface. Understory kelp is fixed to the seabed. Broken understory or floating kelp may be carried downstream in the middle of the water column (prior to settling on the bottom or floating to the surface) and could tangle turbine rotors. Kelp grows fastest during spring and summer, so any bio-fouling due to kelp would be worst during these seasons [10,11]. In addition to kelp, large barnacles will rapidly grow on submerged surfaces in Tacoma Narrows [10]. Any turbine installed in the Narrows will require safeguards against bio-fouling. Anti-fouling paints are the standard method for protecting marine structures, though with some paints there are environmental concerns regarding the leaching of paint toxins into the water over the structure’s lifetime.

Some construction techniques (dredging, water jetting, pile driving) disturb sediments. Sediment dispersion into the water column has two negative impacts: an increase in the opacity of the water (reducing available light) and the potential re-introduction of toxic materials that have settled out of the water column. Tacoma Narrows has been purposely excluded from Washington Department of Ecology sediment contaminant studies [11] since the generally scoured and cobbled nature of the seabed is incompatible with standard sampling equipment. While sediment composition may be inferred from measurements north and south of the Narrows [17], a more rigorous study may be required prior to approval of construction permits.

3. Marine Current Turbines

The Marine Current Turbine (MCT) SeaGen free flow water power conversion device has twin open axial flow rotors (propeller type) mounted on “wings” either side of a monopile support structure which is installed in the seabed. Rotors have full span pitch control and drive induction generators at variable speed through three stage gearboxes. Gearboxes and generators are submersible devices, with casings directly exposed to the passing sea water for efficient cooling. A patented and important feature of the technology is that the entire wing together with the rotors can be raised up the pile above the water surface for maintenance. Blade pitch is rotated 180° at slack water to accommodate bi-directional tides without a separate yaw control mechanism. This device is illustrated in Figure 14.



Operation

Maintenance

Figure 14 – MCT SeaGen (courtesy of MCT)

3.1. Device Performance

Given a velocity distribution for a site, the calculation of extracted and electrical power is discussed in [4]. Site surface velocity distributions have been adjusted to hub height velocity assuming a 1/10th power law, consistent with turbulent flow.

The overall efficiency of the MCT SeaGen is the product of:

- Rotor: constant efficiency = 45%
- Gearbox: maximum efficiency = 96%
- Generator: maximum efficiency = 98%

The efficiency of the gearbox and generator (together termed balance of system efficiency) is a function of the load on the turbine (% load). Power take off (PTO) efficiency is assumed to follow the same form as for a conventional wind turbine drive train – which is approximated by

$$\eta_{PTO} = 0.8337e^{0.1467(\%Load)} - 0.7426e^{-33.89(\%Load)} \quad [18]$$

This function is capped at 94% - the product of maximum gearbox and generator efficiency.

Performance of the turbine over a range of flow velocities is given in Table 4. The turbine is assumed to be installed at a depth of 56m (MLLW reference), consistent with the design of the commercial plant discussed in Chapter 6. The following definitions are used:

- *Flow velocities* are depth adjusted using a 1/10 power law and represent the bin midpoint of the fluid speed at hub-height of the TISEC device.
- *% Cases* represents the percentage of time the flow at the site is at the flow velocity
- *% Load* represents the electrical output as a percentage of rated output of the device
- *Power flux* shows the incident power per square meter at the referenced velocity
- *Flow power* is the power passing through the cross sectional area of the device
- *Extracted Power* shows the amount of power extracted by the device
- *PTO Efficiency* shows the efficiency of the power take-off (generator, hydraulics)

Annual average values for velocity and power generated are given in the last row of the table.

Table 4 – Device Performance at Pt. Evans

Flow Velocity (m/s)	% Cases	% Load	Power Flux (kW/m ²)	Flow Power (kW)	Extracted Power (kW)	PTO Efficiency	Electric Power (kW)
0.09	7.41%	0.0%	0.00	0	0	9.38%	0
0.27	8.29%	0.3%	0.01	5	0	16.13%	0
0.44	8.73%	1.3%	0.04	23	0	36.54%	0
0.62	9.56%	3.7%	0.12	63	0	62.66%	0
0.80	9.57%	7.9%	0.26	133	60	79.18%	47
0.98	9.28%	14.4%	0.48	243	109	84.58%	92
1.15	8.62%	23.7%	0.79	401	181	86.30%	156
1.33	7.47%	36.4%	1.21	616	277	87.95%	244
1.51	7.09%	53.1%	1.76	897	404	90.12%	364
1.69	6.39%	74.1%	2.46	1252	564	92.94%	524
1.87	5.19%	100.0%	3.32	1691	761	94.08%	716
2.04	4.08%	100.0%	4.37	2222	761	94.08%	716
2.22	3.10%	100.0%	5.61	2853	761	94.08%	716
2.40	2.07%	100.0%	7.06	3594	761	94.08%	716
2.58	1.37%	100.0%	8.75	4453	761	94.08%	716
2.75	0.85%	100.0%	10.69	5440	761	94.08%	716
2.93	0.49%	100.0%	12.89	6562	761	94.08%	716
3.11	0.29%	100.0%	15.38	7829	761	94.08%	716
3.29	0.13%	100.0%	18.17	9249	761	94.08%	716
3.46	0.01%	100.0%	21.28	10831	761	94.08%	716
3.64	0.00%	100.0%	24.73	12585	761	94.08%	716
3.82	0.00%	100.0%	28.53	14517	761	94.08%	716
4.00	0.00%	100.0%	32.69	16639	761	94.08%	716
4.17	0.00%	100.0%	37.25	18957	761	94.08%	716
4.35	0.00%	100.0%	42.21	21482	761	94.08%	716
Average 1.09			1.54	785	251		230

A comparison of flow power to electric power generated is shown in Figure 15. Note particularly the cut-in speed (below which no power is generated) and rated speed (above which the power generated is constant).

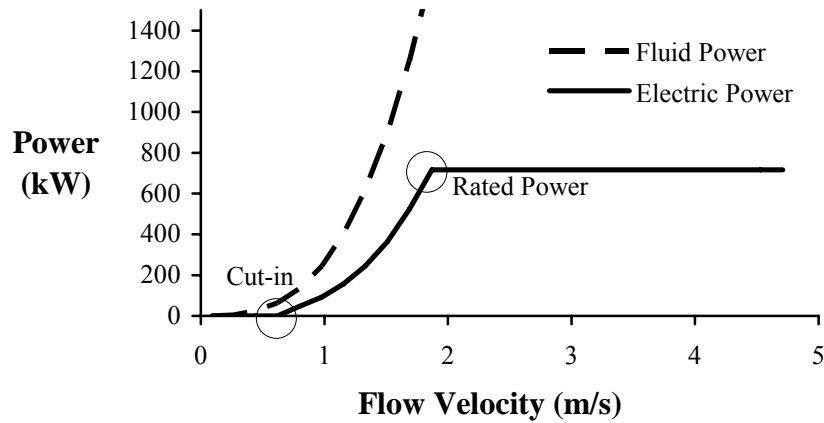


Figure 15 – Comparison of Flow and Electric Power at Pt. Evans

The electrical output of the turbine compared to the fluid power crossing the swept area of the rotor is given in Figure 16, for a representative day. The effect of truncating turbine output at rated conditions is obvious.

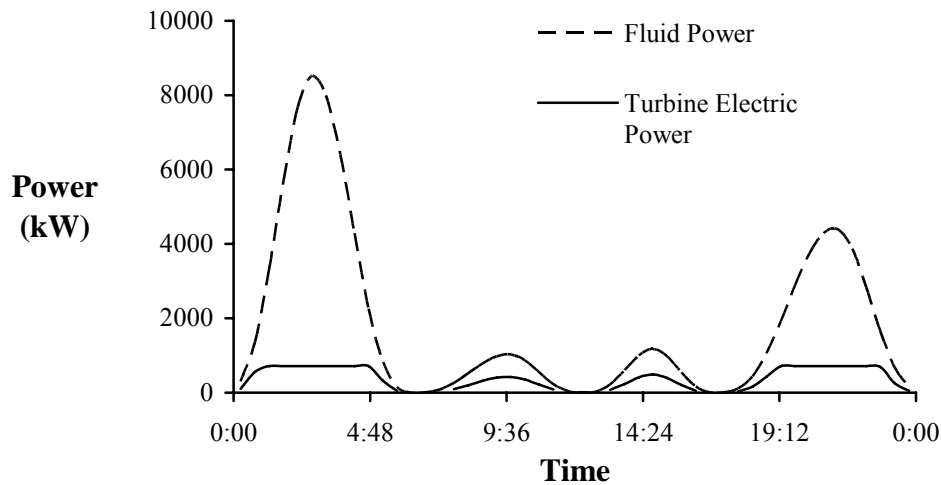


Figure 16 – Daily Variation of Flow and Electric Power at Pt. Evans (February 9th, 2005)

3.2. Device Specification

While in principle SeaGen is scalable and adaptable to different site conditions in various ways, EPRI used the 18m dual rotor version and optimized the system to local site conditions to estimate device cost parameters. The following provides specifications which are later used to estimate device cost. Please note the water depth of 30m, which is not representative of the commercial plant. However, since aspects of the submerged MCT

design are conceptual, 30m installation for a SeaGen device was chosen as a baseline cost. The assumption is that fully submerged, deeper water devices would have similar capital costs. MCT believes that there are substantial opportunities for further cost reduction relative to SeaGen in a next-generation design, but since these are conceptual, a conservative assumption of comparable cost is used here.

Table 5 – SeaGen Device Specification for Target Site

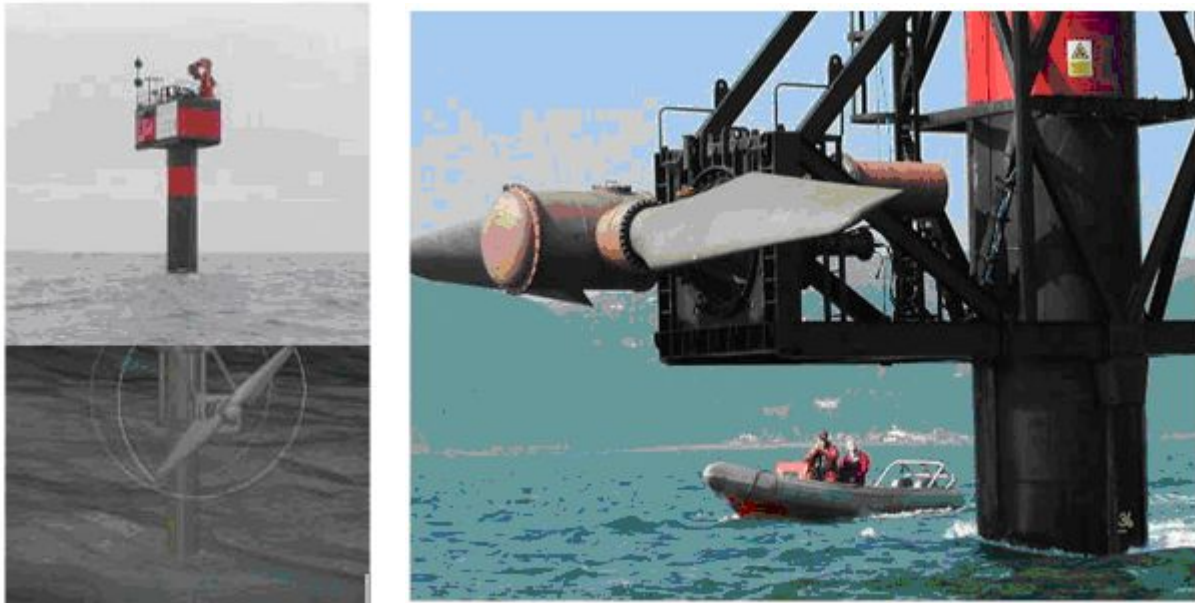
Generic Device Specs	
Speed Inreaser	Planetary gear box
Electrical Output	Synchronized to grid
Foundation	Monopile drilled or driven into consolidated sediment
Water Depth	30m
Dimensions	
Pile Length	68m
Pile Diameter	3.5m
Rotor Diameter	18m
# Rotors per SeaGen	2
Rotor Tip to Tip spacing	46m
Hub Height above Seafloor	17m
Weight Breakdown	
Monopile	213 t
Cross Arm	77 t
Total steel weight	290 t
Performance	
Cut-in speed	0.7 m/s
Rated speed (optimized to site)	1.87 m/s
Rated Electric Power	716 kW
Capacity Factor	30%
Availability	95%
Transmission losses	2%
Net annual generation at bus bar	1875 MWh

The optimized rated speed for the site is somewhat lower than MCT would typical rate a SeaGen. This is ascribed to the diurnality of tides in Tacoma Narrows, which skews the velocity distribution further left than for sites without such a high degree of diurnality.

3.3. MCT Device Evolution

MCT has been experimenting with a 300kW single rotor test rig, SeaFlow (Figure 17), near Lynmouth since 2003. A 1.2 MW prototype SeaGen is presently being built and is scheduled for UK deployment in the fall of 2006. SeaGen is intended as a commercial prototype (not proof of concept) – and incorporates important learnings from SeaFlow.

SeaFlow tested many of the features of SeaGen and has informed the design process by providing large amounts of data. The photo shows the rotor out of the water for maintenance – the submersible gearbox and generator are clearly visible. The rotor diameter is 11m and the pile diameter is 2.1m. Within the next year, SeaFlow should be decommissioned [20].



Operation

Maintenance

Figure 17 – MCT SeaFlow Test Unit (courtesy of MCT)

MCT's first commercial unit, the SeaGen has been designed for a target water depth of less than 50m using a surface piercing monopile, which will allow low cost access to the device's critical components such as the rotor, power conversion system, gearbox etc. This configuration is the one shown in Figure 14. This is the device configuration (with an 18m diameter rotor) that has been adopted for the pilot plant.

This configuration is not necessarily suitable for all sites for two reasons. First, deployment in deep water would be difficult and expensive. At a minimum there is significantly more uncertainty in installation costs. Second, surface piercing turbines may be incompatible with tidal channels with shipping traffic. Depending on the authorities involved, installation of surface piercing turbines may be limited to the periphery of shipping channels or disallowed entirely.

Since a number of prospective sites in North American are located in deeper water or in shipping channels, MCT is considering a number of conceptual designs for deep-water, non-surface piercing installations. These next-generation devices would use the same power train as the SeaGen, but attached to a different support structure. Figure 18 shows a conceptual illustration of such a design.

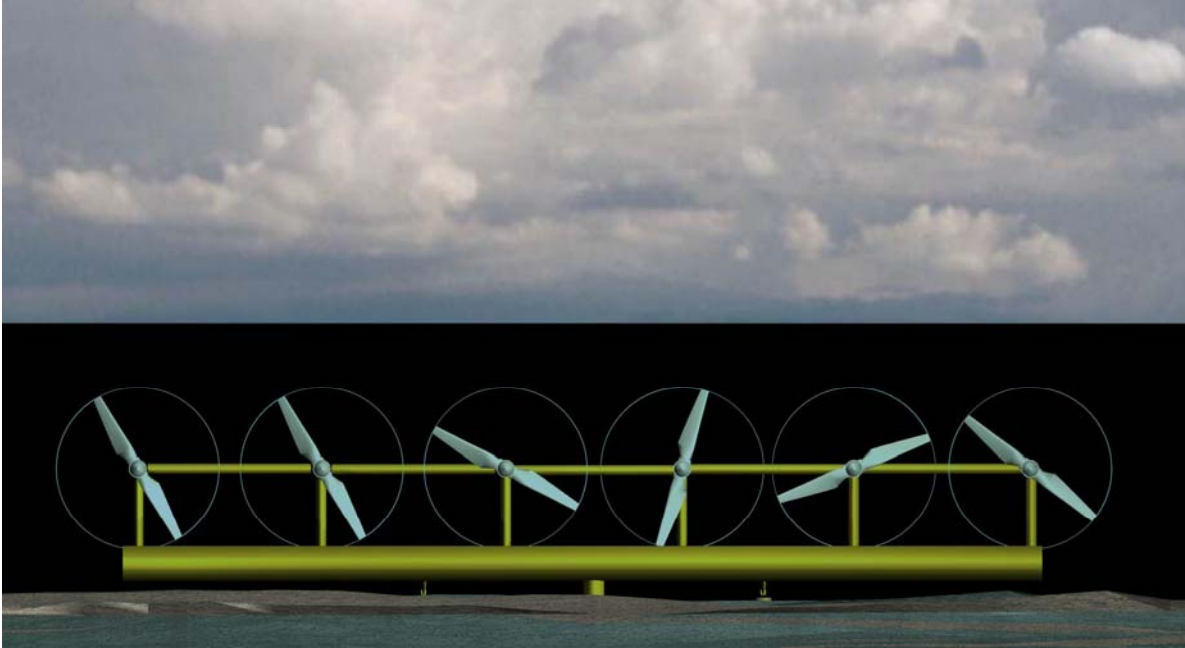


Figure 18 - Conceptual MCT deep water configuration (courtesy of MCT)

A lifting mechanism (type to be determined) to surface the array for maintenance and repair without the use of specialized craft remains an integral part of MCT's design philosophy and would be present in any next-generation design. MCT is also investigating the use of gravity foundations instead of monopiles for certain sites.

MCT anticipates that maintenance of a completely submerged turbine will be more complicated than for a surface piercing structure. As a result, deployment of completely submerged turbines is contingent upon proving the reliability of the SeaGen power train.

3.4. Monopile Foundations

The MCT SeaGen is secured to the seabed using monopile foundation. Figure 19 shows a representative simulation of seabed/pile interaction. Near the surface, the seabed yields due to stresses on the pile, but deforms elastically below a certain depth [24].

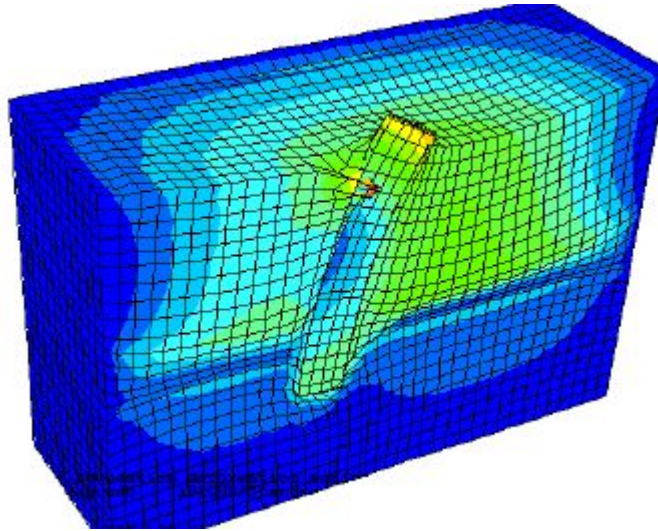


Figure 19 - Simulation of pile-soil interaction subject to lateral load [23]

Simulations such as the one shown above require detailed knowledge of the local soil conditions. Because this study did not perform any detailed geophysical assessment, three different types of soil conditions were chosen to model the pile thickness based on a simplified mechanical model:

- Bedrock
- Bedrock with 10m of sediment overburden
- Soft sediments

The design criterion was to limit maximum stresses to 120N/mm^2 and account for corrosion over the pile life. For Tacoma Narrows, the heavily consolidated sand and gravel seabed is modeled as bedrock with 10m of sediment overburden.

Figure 14 shows the pile weight as a function of design velocity (the maximum occurring fluid velocity at the site) and soil conditions. These curves were then directly used to estimate capital costs of the piles depending on local site conditions. While the model is

well suited for a first order estimate, it is important to understand that the detailed design phase may show significant deviation from EPRI's base model.

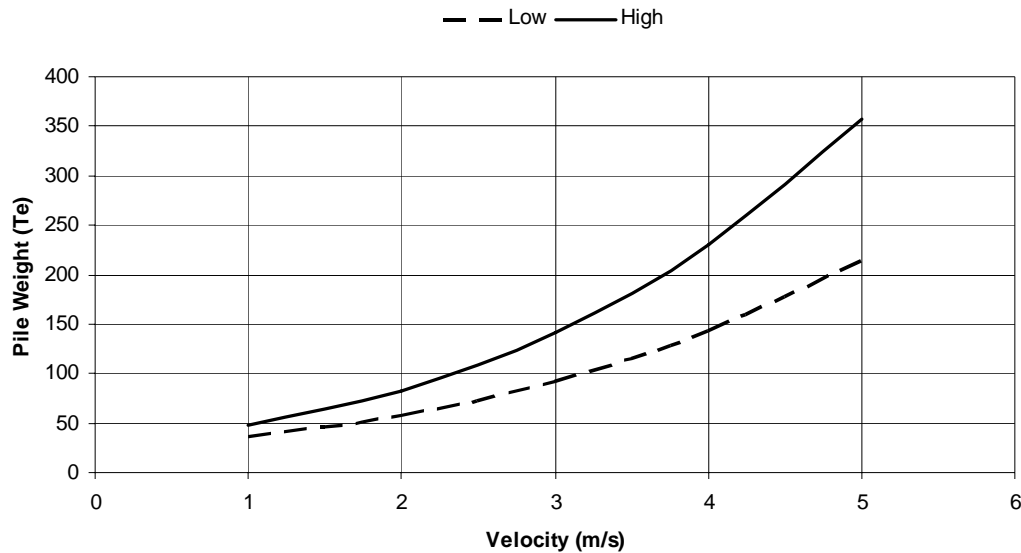


Figure 20 - Pile Weight as a function of design velocity for different sediment types

3.5. Pile Installation

MCT proposes to install their large diameter monopiles (3.5m - 4m outer diameter) using a jack-up barge. This is consistent with other European offshore wind projects that have used such jack-up barges to deploy offshore wind turbine foundations. Jack-up barges operate as follows [19]:

- Barge is towed into position with jack-up legs (4-8) raised
- During period of slack water, legs are lowered to seabed and forces on each leg are equalized. Mats built into the bottom of the legs reduce scour potential. If legs are lowered in high currents they may be damaged.
- Barge jacked up out of water. Platform is now stable and does not require additional mooring to maintain position in high currents.
- At the completion of the project, this process is reversed. Water jetting may be required to free the legs from certain types of seabeds (e.g. consolidated clay).

The following outline (Figure 21) shows the installation of a pile in bedrock from a jack-up barge.

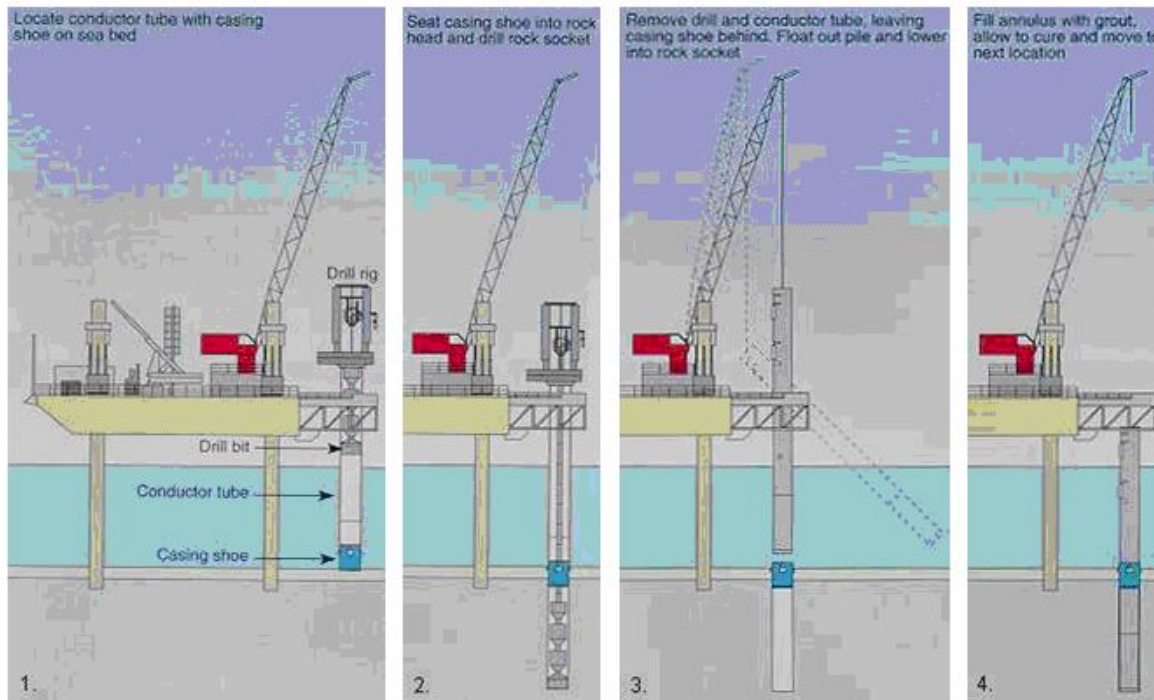


Figure 21 – Pile Installed in Bedrock (courtesy of Seacore Ltd.)

While a few operators were found on the east coast that use jack-up barges, most of them are used in the Gulf of Mexico and no suitable jack-up barges were found on the US west coast for the San Francisco, Washington and Alaska sites. In addition to the expense of mobilizing equipment from the Gulf of Mexico, jack-up barges are six times more likely to suffer serious damage or loss during relocation or transit than while in operation on site. As a result, EPRI decided to investigate alternatives.

While jack-up barges are not commonly available in US waters, there are a significant number of crane barges available from which the installation of large diameter piles could be carried out. These derrick barges operate on the US west and east coast and are extensively used for construction projects in heavy currents such as rivers. Typical construction projects include the construction of bridges, cofferdams and pile installations. Crane capacities vary from about 30 tons all the way up to 600 tons. To carry out the installation of these relatively large 3.5m diameter piles, it was determined that a crane capacity of about 400 tons or more would be adequate to handle the piles, drilling bits and

vibratory hammers. Figure 22 shows Manson Construction's 600 ton derrick barge WOTAN doing construction work on an offshore drilling rig. Two tug boats are used for positioning the derrick barge and set moorings if required.



Figure 22 - Manson Construction 600 ton Derrick Barge WOTAN operating offshore (courtesy of Manson Construction)

In heavy currents these barges use a mooring spread that allows them to keep on station and accurately reposition themselves continuously using hydraulic winches controlled by the operator. This is in contrast to the fixed anchoring function of a jack-up barge leg.

Working from a barge, rather than from a jack-up platform does not set hard limits on the water depth in which piles can be installed (in a jack-up the length of the legs sets the limit on installation depth). In the offshore industry, piles are oftentimes used as mooring points for offshore structures. Installation of driven piles in water depths of more than 300m is not uncommon. It is, however, clear that pile installation in deeper waters becomes more costly and presents a limiting factor to their viability (e.g. a long follower between pile and hammer might be needed in deep water).

While monopile foundations are used extensively in US waterways for the construction of bridges and piers, installation of piles in Tacoma Narrows would be under relatively challenging conditions. Several options exist for installing piles in hardpan, but it is important to stress that west coast marine construction companies have limited experience with such methods in deep, high current waters. Potential construction methods include:

- Driving piles using a hydraulic hammer
- Combination of water jetting and vibratory hammer
- Drill and socket a sleeve, then grout pile in place

Each of these methods has advantages and disadvantages.

The force required to drive a large diameter pile into hardpan using a hydraulic hammer is quite high, and could involve mobilization of a suitably powerful hammer (>1,000,000 ft-lbs/blow) from Europe [21]. Driving a pile with this much force could induce significant fatigue and compromise structural integrity [20]. One potential installation procedure might consist of driving the pile to refusal⁵, cleaning out the inside of the pile can, and driving again until a suitable depth has been reached. It may also be necessary to break up the hardpan around the pile perimeter using water jets if exterior skin friction leads to refusal [19, 21]. Driven pile supports for the tower foundations of the new Tacoma Narrows Bridge were considered during the design phase, but rejected in favor of caissons due to concerns over installation equipment availability [14].

Since hardpan readily breaks up under water jetting, a combination of water jetting and vibratory hammering could be lower cost option to hammering alone since a suitable hammer could be mobilized at lower cost. Installation procedure would consist of water jetting to break up sediments, driving the pile, additional jetting, etc. Once the pile reaches specified depth, the hammer would act on the pile for a number of additional strikes, helping to reconsolidate the disrupted sediments [19]. However, environmental regulation may restrict the use of water jetting since it results in significant sediment disruption [21].

⁵ Refusal is defined as 1000 blows/meter penetration or 800 blows for 0.3meter penetration.

A drilled pile installation would involve drilling into the consolidated sediments and stabilizing the walls of the drill hole with a metal sleeve. Once the hole has been drilled to a suitable depth, the pile is inserted and grouted into place. This method of installation is preferred by MCT to limit excessive pile fatigue during the installation process [20] and equipment for drilling could be mobilized from Europe. Marine Construction companies contacted in Puget Sound agreed that such an installation would be possible, though challenging in Tacoma Narrows [21, 22]. Drilled piles were also considered for the new bridge tower foundations, but rejected due to the depth of drilling required and concerns over installation equipment availability [14].

For the purposes of this feasibility study, it is assumed that pile installation would be by drilling. A detailed design which incorporates the findings of a site-specific geotechnical survey will be required to determine the most economic option.

3.6. Operational and Maintenance Activities

The guiding philosophy behind the MCT design is to provide low cost access to critical turbine systems. MCT feels this is especially important since the majority of unplanned interventions during the SeaFlow demonstration involved minor problems or false alarms [20]. Since the integrated lifting mechanism on the pile can lift the rotor and all mechanical subsystems out of the water, general maintenance activities do not require specialized ships or personnel (e.g. divers). Furthermore, for major repairs or scheduled refits, a barge can be positioned under the power train for relatively simple dismounting.

The overall design philosophy appears to be that the risks associated with long-term underwater operation are best offset by minimizing the cost of scheduled and unscheduled maintenance tasks. The only activities that could require use of divers or ROVs would be repairs to the lifting mechanism or inspection of the outer surface of the monopile, none of which are likely to be required over the project life.

Annual inspection and maintenance activities are carried out using a small crew of 2-3 technicians on the device itself. Tasks involved in this annual maintenance cycle include

activities such as replacement of gearbox oil, applying bearing grease and changing oil filters. In addition, all electrical equipment can be checked during this inspection cycle and repairs carried out if required. Access to the main structure can be carried out safely using a small craft such as a RIB (Rigid Inflatable Boat) in most sea conditions. Since Tacoma Narrows experiences little wave action, maintenance intervention should be feasible year-round.



Figure 23 - Typical Rigid Inflatable Boat (RIB)

For repairs on larger subsystems such as the gearbox, the individual components can be hoisted out with a crane or winch and placed onto a motorized barge which is a relatively low cost vessel. The barge can then convey the systems ashore for overhaul, repair or replacement. For the purpose of modeling O&M costs, the mean time to failure was estimated for each component to determine the resulting annual operational and replacement cost. Based on wind-turbine data, the most critical component is the gearbox which shows an average mean time to failure of 10.8 years.

For the next generation design for a completely submerged turbine (assumed for commercial plant) major intervention could require the use of a crane barge to dismount the power train from the support structure. Since the lifting mechanism would also be subsurface, a failsafe retrieval method (e.g. retrieval hook) would be required in the case of a failure of the lifting mechanism. MCT does not anticipate the added complexity of full

submergence to greatly increase maintenance costs, because deployment of a fully submerged device is contingent on proving power train reliability [20].

Barges for major maintenance activities could be mobilized from any of the area ports – Tacoma, Seattle, or Olympia. For minor maintenance, small craft could be launched directly from a beach along the Narrows or mobilized from Gig Harbor.

4. Electrical Interconnection

Each TISEC device houses a step-up transformer to increase the voltage from generator voltage to a suitable array interconnection voltage. The choice of the voltage level of this energy collector system is driven by the grid interconnection requirements and the array electrical interconnection design but is typically between 12kV and 40kV. For the pilot scale, 12kV systems are anticipated – depending on local interconnection voltages. This will allow the device interconnection on the distribution level. For commercial scale arrays, voltage levels of 33kV are used. This allows the interconnection of an array with a rated capacity of up to about 40MW on a single cable. While there is little incremental cost in increasing turbine output voltage from 12 to 40kV (different step-up transformer required), above 40kV the cost of circuit breakers, interconnection, overvoltage protection, etc. increase dramatically. As a result, it is not feasible to step-up turbine generator voltage to transmission line voltage levels (115 kV) at the turbine. However, once commercial array cables have been brought ashore, they may be readily stepped up to transmission line voltages.

A generalized array interconnection scheme is shown in Figure 24. Power generated by a cluster, or transect, or turbines is aggregated and landed onshore where it feeds into the grid.

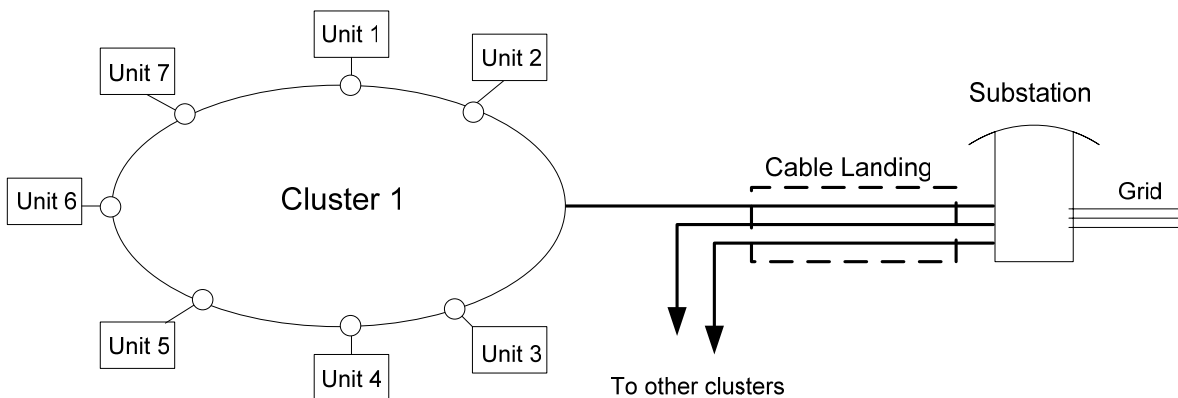


Figure 24 – Generalized interconnection for turbine array

A fiber optic core is used to establish reliable communication between the devices and a shore-based supervisory system. Remote diagnostic and device management features are important from an O&M stand-point as it allows to pin-point specific issues or failures on

each unit, reducing the physical intervention requirements on the device and optimizing operational activities. Operational activities offshore are expensive and minimizing such interventions is a critical component of any operational strategy in this harsh environment.

For the surface piercing MCT SeaGen device (pilot plant), most electrical components are located inside the top of the monopole, where they are well protected and easily accessible for operation and maintenance activities. No sub sea connectors or junction boxes are required to interconnect the device to the electrical grid. A fully submersed MCT device (commercial plant) would not require a junction box either, but would require a J-tube to guide the subsea cable up to the power train.

4.1. Subsea Cabling

Umbilical cables to connect turbines to shore are being used in the offshore oil & gas industry and for the inter-connection of different locations or entire islands. In order to make them suitable for in-ocean use, they are equipped with water-tight insulation and additional armor, which protects the cables from the harsh ocean environment and the high stress levels experienced during the cable laying operation. Submersible power cables are vulnerable to damage and need to be buried into soft sediments on the seabed or otherwise protected. While traditionally, sub-sea cables have been oil-insulated, recent offshore wind projects in Europe, showed that the environmental risks prohibit the use of such cables in the sensitive coastal environment. XLPE insulations have proven to be an excellent alternative, having no such potential hazards associated with its operation. Figure 25 shows the cross-sections of armored XLPE insulated submersible cables.



Figure 25 – Armored submarine cables

For this project, 3 phase cables with double armor and a fiber core are being used. The fiber core allows data transmission between the units and an operator station on shore. In order to protect the cable properly from damage such as an anchor of a fishing boat, the cable must either be trenched into the seabed or shielded. In general, a trench is carved in the seabed, the cable is laid down, and this channel is then back-filled with rocks. Various trenching technologies exist such as the use of a plough in soft sediments, use of a subsea rock-saw in rock (if going through hard-rock) or the use of water jets in consolidated sediments. All of these cable laying operations can be carried out from a derrick barge that is properly outfitted for the particular job. The choice of technology best suited for getting the job done depends largely on the outcome of detailed geophysical assessments along the cable route. For this study, the EPRI team assessed both the use of a trenching rock saw as well as a plough.

An important part of bringing power back to shore is the cable landing. Existing easements should be used wherever possible to drive down costs and avoid permitting issues. If they do not exist, directional drilling is the method with the least impact on the environment. Directional drilling is a well established method to land such cables from the shoreline into the ocean and has been used quite extensively to land fiber optic cables on shore. Given some of the deployment location proximity to shore, detailed engineering might even reveal that directional drilling directly to the deployment site is possible. This would reduce environmental construction impacts at the site, while reducing overall cost.

4.2. Onshore Cabling and Grid Interconnection

Traditional overland transmission is used to transmit power from the shoreline to a suitable grid interconnection point. Grid interconnection requirements are driven by local utility requirements. At the very least, circuit breakers need to be installed to protect the grid infrastructure from system faults. VAR compensation and other measures might be introduced based on particular requirements. The peak power output of the plant will determine the appropriate grid interconnection voltage.

5. System Design – Pilot Plant

The purpose of a pilot plant is first, and foremost, to demonstrate the viability of a particular technology. Pilot plants are, in general, not expected to produce cost competitive electricity and often incorporate instrumentation absent from a commercial device. The pilot plant is assumed to consist of a single MCT SeaGen installed in 35m water off Point Evans. While a true pilot should use the same technology as a commercial plant, this will not be possible for a turbine installed in the immediate term since (as discussed in Chapter 6) a commercial plant would have to be fully submerged due to shipping considerations. However, provided that a fully submerged next-generation MCT device would incorporate the same rotor and power train as a SeaGen and the support structure would continue to use pile foundations, there is significant value in deploying a SeaGen pilot. For the commercial plant, it is assumed that fully submerged turbines at Point Evans would not be the first ever worldwide installation (much as a SeaGen at Point Evans would not be the first installation of that device). As a result, the hope would be that regulatory concerns associated with the use of a different support structure could be satisfied without a second full-scale pilot test. The selection of a SeaGen for the pilot is intended to balance the competing interests of large-scale site deployment against a desire to deploy a pilot turbine in the immediate term.

For the pilot TISEC plant, the following should be successfully demonstrated prior to installation of a commercial array:

- Turbine output meets predictions for site.
- Installation according to design plan with no significant problems.
- Turbine operates reliably, without excessive maintenance intervention.
- No significant environmental impacts for both installation as well as operational aspects.

For the pilot plant at Tacoma Narrows, the following issues deserve particular attention and should be an integral part of the pilot testing plan:

- Large marine mammal and fish interaction with turbine – particularly primitive sharks with habitat near seabed. This will require instrumentation for fish and marine mammal monitoring.
- Bio-accumulation (kelp and barnacles) on turbine and support structure over course of demonstration. Given the biologically active nature of Puget Sound, bio-accumulation may occur at a more rapid rate than other sites.

The pilot plant will consist of a single turbine installed as close to Pt. Evans as surface and seabed clearance restrictions allow. Since the pilot will be surface piercing, 4m overhead clearance at LAT is assumed. A figure showing a possible deployment location for the pilot turbine and associated electrical infrastructure is given in Figure 26. The white rectangle designates the pilot turbine and red and black lines designate transmission infrastructure.

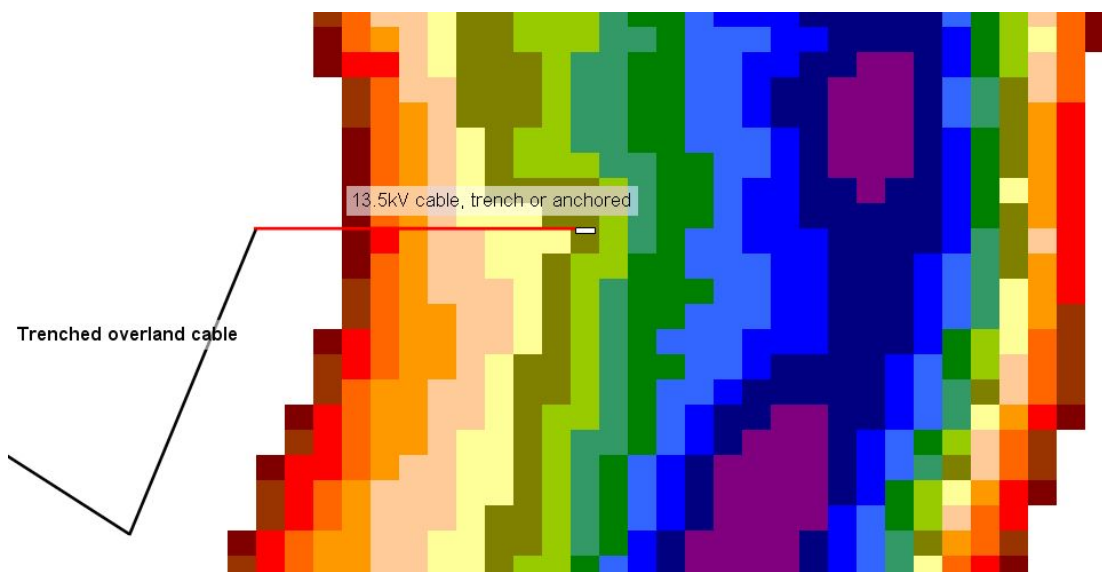


Figure 26 – Pt. Evans Pilot Plant Layout

By siting the pilot turbine near the apex of Pt. Evans, the turbine should not operate in the wake that forms around the point during ebb and flood tides. Since the wake is a prime sport fishing location, keeping the turbine out of the wake also limits multiple use conflicts. The turbine would be installed in water approximately 35m deep (MLLW reference) in close proximity to the reference location for Pt. Evans NOAA current prediction.

As can be seen from this figure, the footprint of the pilot plant is quite small and should have little impact on recreation or shipping activities within the Narrows. Assuming that the conventional shipping lane (no official shipping lane is designated for Tacoma Narrows) follows the deep water channel, the chosen deployment site should be just outside the conventional shipping lane. Note that there is insufficient space at Point Evans to install more than a few surface piercing devices due to the competing restrictions of shipping traffic and headland eddies.

The following illustration shows how a single TISEC device is connected to the electric grid.

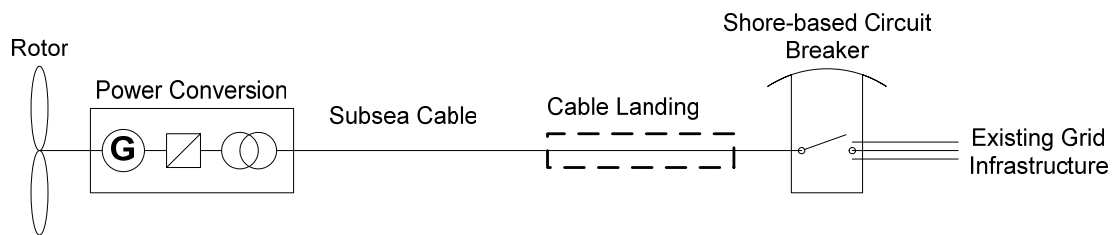


Figure 27 - Conceptual Electrical Design for a single TISEC Unit

The turbine will output AC power at 12.47kV. Power will be taken off via subsea cable (13.5kV rated to 1 MW) trenched into or anchored to the seabed. The cable will be brought on-shore at Pt. Evans on Tacoma Power property (ROW) just south of the Pt. Evans channel marker. On-shore, the cable could be trenched along the route of an existing footpath which runs from the beach to the 115kV line crossing towers. From here, the line would have to either be underbuilt⁶ for approximately one-half mile to a Peninsula Power and Light (Pen Light) substation or connected directly with a Pen Light distribution line. Since the latter option might require load matching, utility T&D planners are uncertain which option would be preferred. Connection with the distribution line has been chosen for the purposes of pilot design.

⁶ Routed on the 115 kV utility poles approximately 20 feet below the existing lines

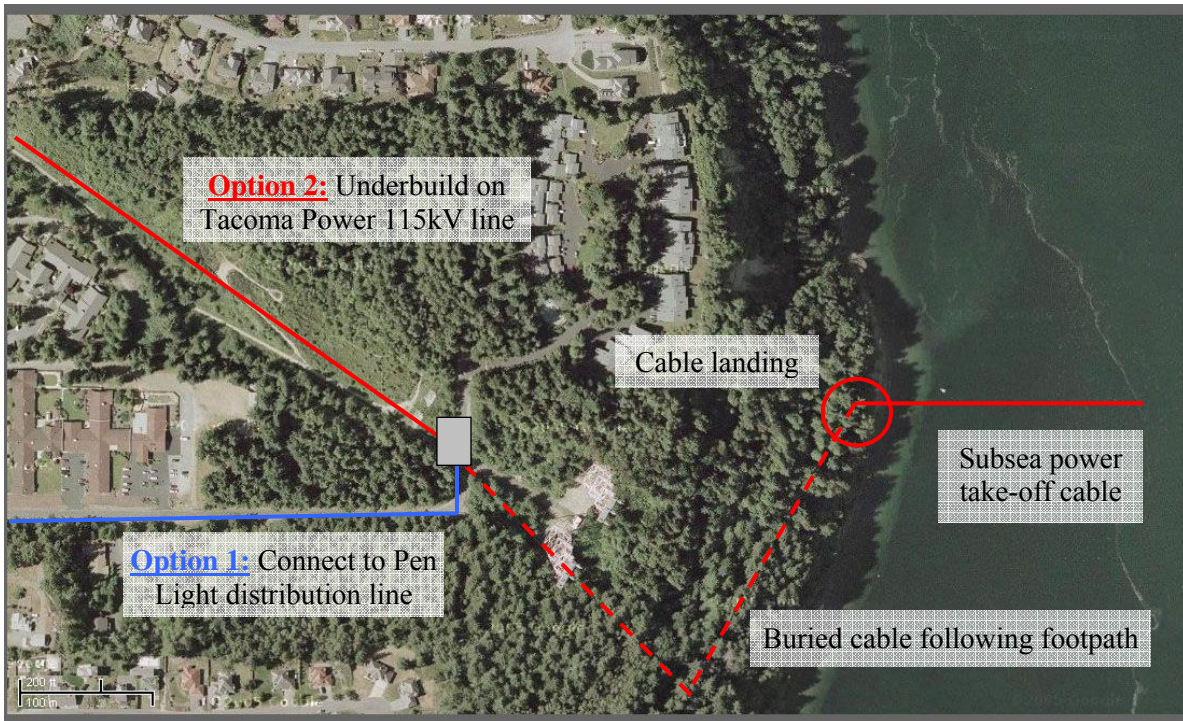


Figure 28 – Pilot Plant Interconnection

Pilot grid interconnection details are summarized in Table 6. The cost for overland interconnection is for routing the power take-off cable from the beach to distribution line. Infrastructure upgrade costs would be for pole-mounted equipment and are expected to be minor. Costs are described further in Chapter 7.

Table 6 – Pilot Grid Interconnection

Offshore Cable	
Cable Length	570 m
Trench Length	570 m
Sediment type along cable route	Gravel and cobbles
Offshore Interconnection Cost	\$0.7M
Onshore Cable	
Cable Landing	On beach, trenched up to bluffs
Cable Length	450 m
Onshore Interconnection Cost	\$300,000
Infrastructure Upgrade Cost	\$40,000

Assuming resource estimates are accurate for Pt. Evans, the projected power output from the pilot turbine will be as previously discussed – 716kW peak, 214kW on average.

6. System Design - Commercial Plant

The purpose of a commercial tidal plant is to generate cost competitive electricity for the grid. By installing a large number of turbines, economies of scale will decrease unit costs.

The design of a commercial tidal array is driven by the following principles:

- Install turbines only in waters sufficiently deep to meet clearance requirements
- Install sufficient turbines to extract 15% of estimated resource
- Design turbine interconnection for redundancy to maximize array availability

These principles result in the array design shown in Figure 29. The array consists of sixty four (64) dual-rotor, eighteen (18) meter diameter turbines arranged in five (5) transects as designated by white rectangles (approximately to scale). The turbines will be fully submerged during operation. New electrical infrastructure is shown in red. The design is described in more detail in the following sections.

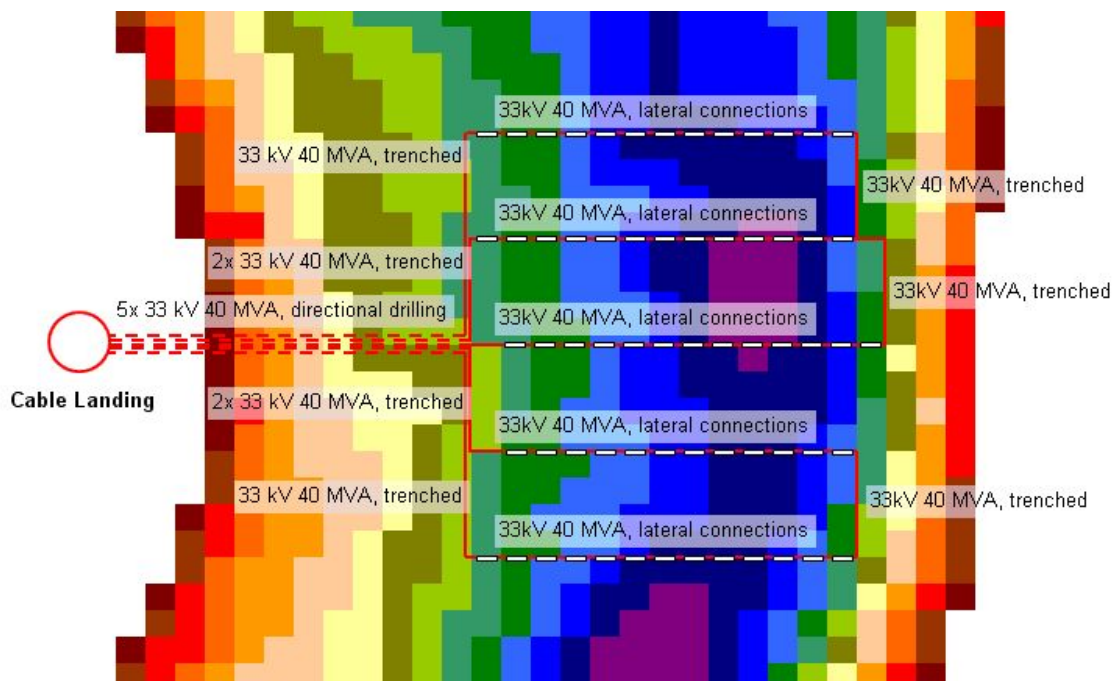


Figure 29 – Pt. Evans Commercial Array Layout

6.1. Array Layout

The commercial array is assumed to consist of dual-rotor MCT turbines which will not be surface piercing. A conceptual design of a fully submerged MCT device is briefly

discussed in Chapter 3. Note that the array layout here is consistent with the dimensions of a fully submerged SeaGen with two rotors and power trains per foundation pile. While straight-line transects are used here, it is worth remembering that based on detailed site velocity data, arrays might be laid out along curves of constant power flux [20].

The layout of the turbine array is governed by the following spacing rules:

- 8m clearance between rotor tip and seabed to prevent cyclic blade stresses due to operation in the boundary layer.
- In shipping channel, 15m clearance between rotor tip and surface to accommodate shipping traffic. Shipping lane is assumed to be the distance between east and west caissons of the Tacoma Narrows Bridge (2800 ft) and is centered on the deep water channel [15].
- Outside the shipping lane, 8m clearance between rotor tip and surface to accommodate pleasure craft.
- 9m clearance between each turbine to prevent lateral interaction between rotors [25].
- 180m (10 turbine diameters) downstream spacing between array transects to allow turbulent dissipation of rotor wake [27].

Note that these spacing rules have been developed based on analogues to wind-turbine array layouts, and require additional modeling and testing to verify.

Since the next-generation, fully submerged turbine is conceptual at this stage, the following assumptions have been made in for design and costing purposes:

- Fully submerged in operation
- Integrated lifting mechanism to bring turbine to surface for maintenance and inspection without use of specialty craft
- Monopile foundation
- Two rotors per supporting foundation (dual-rotor turbine)
- Equipment and installation costs for next-generation MCT turbines in-line with equipment and installation costs for SeaGen type device

Since both the lifting mechanism and support structure for a fully submerged turbine are entirely conceptual, this represents a significant uncertainty in the site assessment. A representative schematic showing clearances and dimensions for the array is shown in Figure 30.

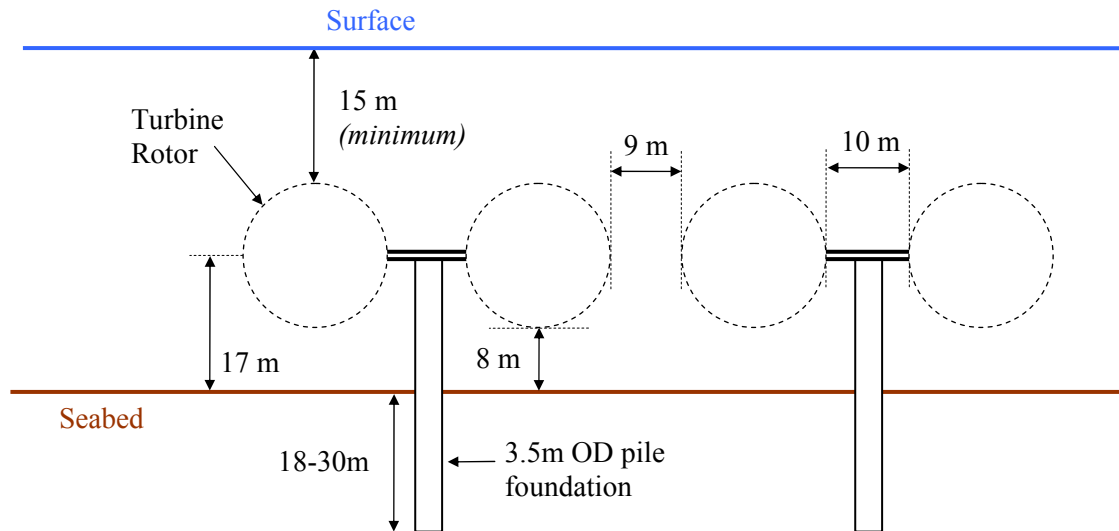


Figure 30 – Turbine Size and Spacing

Array layout is an iterative process. First an array layout is chosen with a specified number of turbines. From this, the average turbine depth may be calculated and used to predict the power output of the array. Using the cost model discussed in Chapter 8, a rated speed is chosen to give the lowest cost of energy (COE). The power extracted by the array is then checked to determine that no more than 15% of the kinetic energy has been removed from the flow. If too much/not enough energy has been removed from the flow turbines are removed/added to the array layout and the process continues until a lowest COE array that extracts 15% of the kinetic energy from the flow has been designed. The number of turbines may be further reduced to limit the peak electric output to feed-in limits appropriate to the site (e.g. 120MW at 115kV).

The Point Evans array consists of sixty-four dual-rotor turbines, arranged in five transects of twelve or thirteen turbines. These will, on average, extract 16 MW of power – 15% of the

average channel power. The mean depth of water for installation is 56m. Installation depths range from 43 – 67m (MLLW reference) as shown in Figure 31.

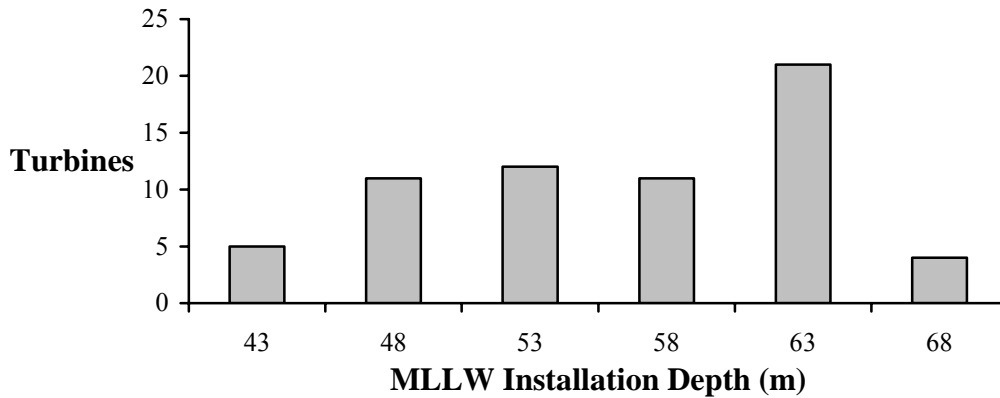


Figure 31 – Pile Installation Depth Distribution

At this depth, monopile installation from a derrick barge should be feasible. Manson Construction has a 400 ton crane barge based out of Seattle which could be used for deployment of the Tacoma Narrows plant for either drilling or driving.

6.2. Electrical Interconnection

As discussed in Chapter 3, the rated electrical output for the dual-rotor devices is 716 kW. The rated power load in MW of each transect is given in Table 7. Turbine transects are as shown in Figure 29 and are numbered sequentially from north to south.

Table 7 – Pt. Evans Transect MVA Ratings

Transect	Turbines	Transect Rating (MW)
1	13	9.3
2	13	9.3
3	13	9.3
4	12	8.6
5	13	9.3

The array will operate at 33kV. Five cables are required to bring the power on shore – one for each transect in order to provide design redundancy. Since all five take-off cables can be laid in a single routing, the incremental cost of shore redundancy is relatively low and has little impact on the cost of energy.

Since multiple cables will be coming ashore and must remain in place for the lifetime of the array, directional drilling from the shoreline bluffs to the array location is the preferred method of cable installation and would require directional drilling for approximately 400m. Since the eddies off Pt. Evans result in continuous sediment movement, burying the main cluster of take-off cables deep enough to prevent exposure over the lifetime of the array is probably not practical. Cables running laterally between turbines and longitudinally between transects are in a more scoured region and could be secured by jetting or plowing them into the seabed. The directionally drilled cables will come ashore on the bluffs above the Pt. Evans channel marker at the northern end of the Tacoma Power property (ROW). Two options exist for interconnection to the 115kV transmission lines. The first option would be to trench the cables along the footpath up to the cable crossing towers (as is suggested for the pilot plant). A new substation would be built near the towers for interconnection with the 115kV lines. Alternatively, depending on the final decision for peak array power output, it might be possible to step-up the voltage to 115kV where the take-off cable comes ashore and tie-in directly to the 115kV lines. These two options are shown in Figure 32.

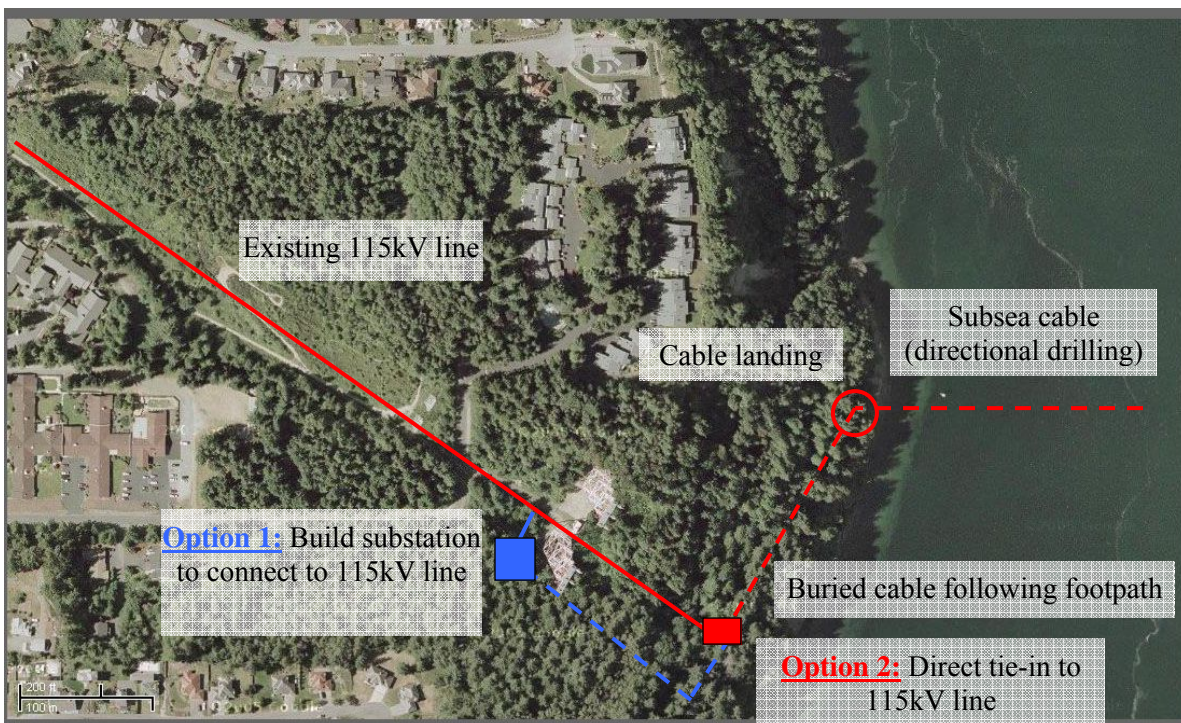


Figure 32 – Commercial Plant Interconnection

Since it is unclear whether the array design will permit direct tie-in, for the purposes of the commercial array design it is assumed that a new substation will have to be constructed at an estimated cost of \$2.5 to \$3M (excluding real-estate). No infrastructure upgrades beyond the high voltage side of the substation transformer are anticipated. An additional \$500,000 is included for cable landing and routing of power cables up to the new substation. Details of the commercial interconnection plan are given in Table 8. Costs are described further in Chapter 8.

Table 8 – Pt. Evans Commercial Array Grid Interconnection

Offshore Cable	
Cable Length	3900 m
Trench Length	1700 m
Directional Drilling Length	400 m
Sediment type along cable route	Mud and sand
Offshore Interconnection Cost	\$10.4M
Onshore Cable	
Cable Landing	On bluffs
Cable Length	450 m
Overland Interconnection Cost	\$0.5M
Infrastructure Upgrade Cost	\$3.0M

6.3. Array Performance

Array performance calculations are based on the following assumptions:

- Predicted surface velocity at site is valid for the entire region of deployment (see Appendix)
- Flow velocity does not appreciably decay between first row and last row of turbines (see Appendix)
- Average power flux over turbine is approximately the power flux at hub height (see Appendix)
- The mean depth for the site is representative of the depth for all turbines

Using this assumption, the output of the array may be found by multiplying the output of a single, representative turbine by the total number of turbines in the array. Array performance is summarized in Table 9.

Table 9 – Pt. Evans Array Performance

Array Performance	
Number of turbines	64
Number of transects	5
Availability	95%
Transmission Efficiency to Shore	98%
Capacity Factor	30%
Average Extracted Power	16 MW (16 MW extraction limit)
Average Electric Power	13.7 MW
Maximum Electric Power	45.8 MW
Annual Electricity Generation	120,000 MWh

The array power output over a single day, 14-day tidal cycle, and for each month is given in Figure 33, Figure 34, and Figure 36. The truncating effect of the rated power of each turbine is evident in both the daily and tidal cycle plots. Note, transmission losses and availability are not taken into account in the daily or tidal cycle plots, but are accounted for in the monthly averages. Averages are for the period shown on the plots – note that the average power generated for the reference day is higher than the average for the entire year. This indicates a relatively high degree of (predictable) variability in turbine array output. The annual variation is perhaps most easily shown by the daily average array electrical output (Figure 35) over a year.

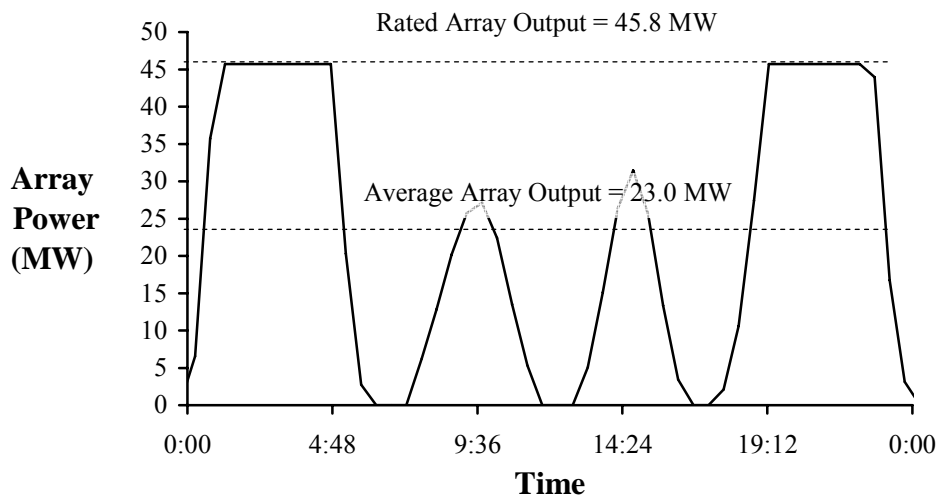


Figure 33 – Daily Array Power Output (February 9th, 2005)

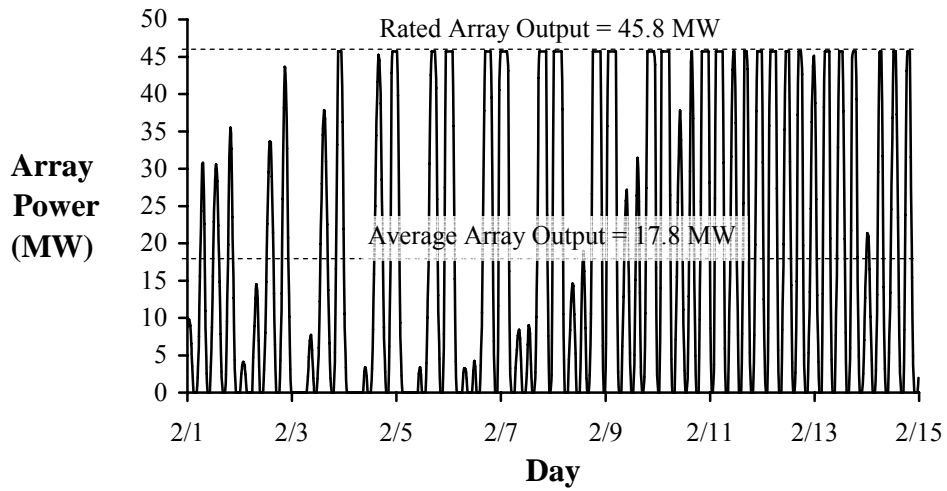


Figure 34 – Tidal Cycle Array Power Output (February 1st-14th, 2005)

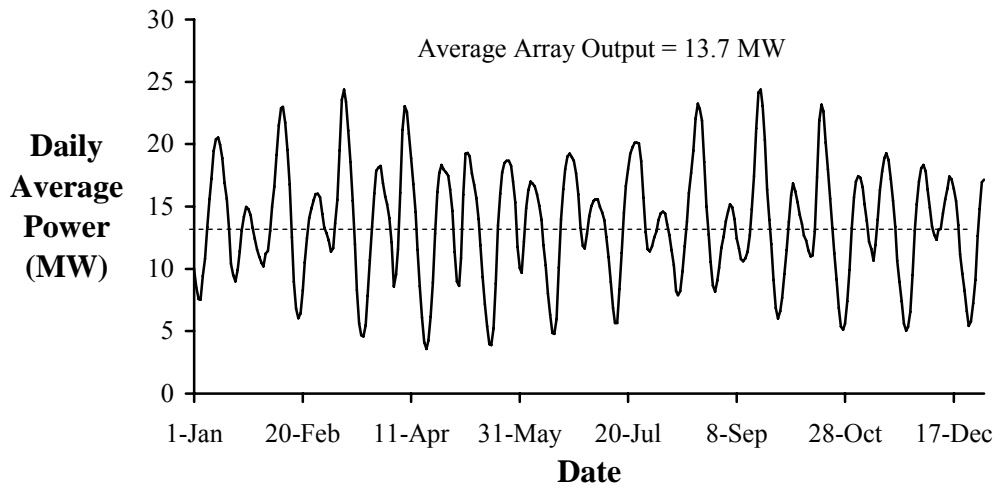


Figure 35 – Daily Average Array Power (2005)

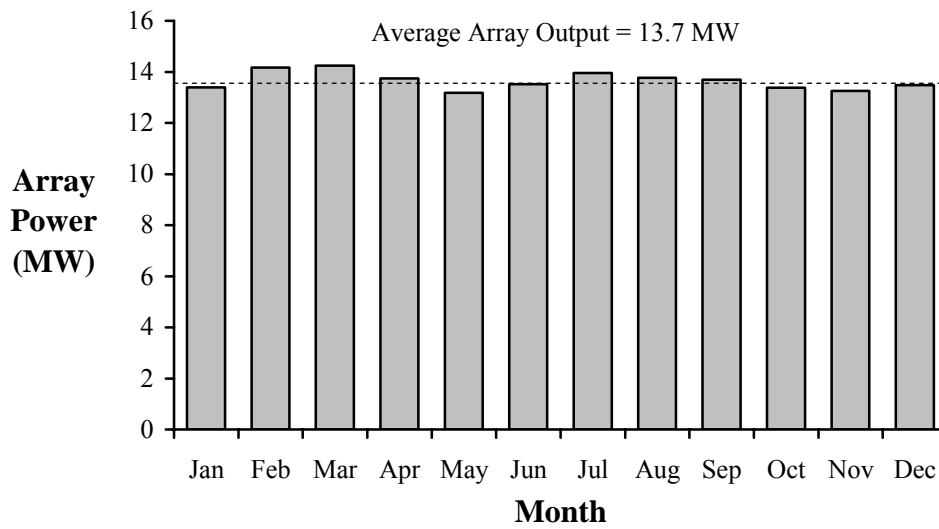


Figure 36 – Monthly Average Array Power Output (2005)

The array power output, while relatively uniform on a monthly or annual basis, shows significant daily and hourly variation due to the tidal cycle. Since generation does not always coincide with peak demand, utilities will need to determine how best to integrate the power generated from a commercial tidal array with their existing generation portfolios.

6.4. Site Specific Issues

Eddies: Turbines should be sufficiently far from Pt. Evans to be unaffected by ebb and flood eddies off the point.

Shipping: Operation of a fully submerged array of turbines with 15m overhead clearance at LAT should in no way restrict shipping traffic in Tacoma Narrows. Installation and maintenance plans should be structured as to minimize interference with shipping. The Marine Exchange of Puget Sound [16] maintains detailed records of shipping traffic in Puget Sound and would be an excellent starting point in modeling shipping traffic patterns.

Multiple Use: If, for safety reasons, no recreational boating, diving, or fishing would be able to take place within the turbine deployment area for safety reasons, the array would require an exclusion area of approximately 1 km², 8% of the total surface area of Tacoma Narrows (12.9 km²). The turbines and cabling occupy an even smaller footprint. This indicates that even if multiple-use restrictions are necessary commercial scale array turbine installation should be compatible with continued recreational use of most of Tacoma Narrows. MCT expects that sport fishing would pose no threat to turbine operation, but net fishing is a greater concern since nets could tangle and damage turbine rotors [20].

Bio-fouling: MCT expects neither kelp nor barnacles to pose any issue to turbine operation. The site of the SeaFlow pilot is also a biologically active marine environment. However, after three years of operation, there has been no substantial bio-accumulation on either rotor or support structure, as shown in Figure 37.



Figure 37 – MCT SeaFlow (courtesy of MCT)

MCT would expect to deploy a glass-based anti-fouling paint to minimize bio-accumulation over the lifetime of the system, as will be the case for the SeaGen demonstration. This type of anti-fouling coating should not leach any materials of significance into the water column. Rope cutters at the hub work to prevent kelp build-up at the base of the rotors [20].

Marine Ecology Impact: Impact on marine life and estuary ecology from an array of TISEC devices of any type is largely theoretical. Due to cavitation concerns, rotor tip velocities are limited to 10-12 m/s. This, in turn, limits the 18m rotors to a rotation rate of 11-13 RPM. This is an order of magnitude lower than rotation rates for ship propellers, reducing the risk of harassment or injury to marine life. The SeaGen installation in Strangford Narrows, UK is also sited within a delicate marine ecosystem and will be instrumented to monitor turbine interaction with marine life [20]. While the data collected at the Strangford site can not substitute for data collection in Tacoma Narrows, it should serve as an instructional proxy.

Since the extracted kinetic energy is restricted to 15% of the flow resource, downstream effects are predicted to be insignificant. Furthermore, numerical models indicate the installation of TISEC arrays may actually *increase* velocity downstream of the turbine [28]. Additional study is required in this area to fully quantify the impact of array operation.

7. Cost Assessment – Pilot Plant

The cost assessment of the demonstration plant was carried out by taking manufacturer specifications for their devices, assessing principal loads on the structure and scaling the devices to the design velocity at the deployment site. While all costing models were developed internally, MCT provided data and support to calibrate the models, which was an important step in developing meaningful and accurate cost models. Installation and operational costs were evaluated by creating detailed cost build-ups for these aspects taking into considerations equipment availability at North American rates. A high-level capital cost breakdown relevant to the deployment site is shown in the table below. Note that the costs in this table do not include any specialty instrumentation or measurement equipment that may be deployed over the course of the pilot to satisfy regulatory requirements for a commercial array.

Table 10 – Pilot Plant Cost Breakdown

	\$/kW	\$/Turbine	%
Power Conversion System	\$1,428	\$1,022,050	24.6%
Structural Steel Elements	\$922	\$659,710	15.9%
Subsea Cable Cost	\$25	\$18,240	0.4%
Turbine Installation	\$2,014	\$1,442,000	34.7%
Subsea Cable Installation	\$944	\$675,842	16.3%
Onshore Electric Grid Interconnection	\$475	\$340,000	8.2%
Total Installed Cost	\$5,808	\$4,157,842	100%

A single unit will cost significantly more than subsequent units installed at the site. Installation costs are dominated by mobilization charges. Additionally, the first unit equipment costs will always be higher than subsequent ones due to learning scale. The assessment of operational and maintenance cost for the pilot was not part of the scope of this study.

It is, however, important to understand that the purpose of the pilot plant is not to provide low cost electricity, but to reduce risks associated with a commercial array. Risks include technological uncertainty in device performance, operation and maintenance requirements, validation of structural integrity, and environmental impact associated with the interaction of the natural habitat with the TISEC device.

8. Cost Assessment – Commercial Plant

Costs for the commercial plant are, as for most renewable energy generating technologies, heavily weighted towards up-front capital. In order to determine the major cost centers of the commercial plant, detailed cost build-ups were created in order to assess them properly in the context of the given site conditions. The major influences on cost for a particular site are discussed below:

Design Current Speed: The design current speed is the maximum velocity of the water expected to occur at the site. Structural loads (and related structural cost) on a structure increase with the square of the fluid velocity. Given the velocity distribution at the site, the design velocity can be well above the velocity at which it is economically useful to extract power. In other words, the design velocity can have a major influence on the cost of the structural elements. During normal operating conditions, the loads on the structure will peak near the rated turbine velocity and decrease thereafter as the turbine blades are pitched to maintain constant power output, decreasing the thrust coefficient on the rotor blades. For conservatism, the design velocity is set to the site peak, rather than device rating, in order to simulate the loads experienced during runaway operation in the event of pitch control failure.

Velocity Distribution: The velocity distribution at the site is outlined in Chapter 2 of this report. As the rated velocity of the device increases, so do power train costs. Since the velocity distribution tails off at higher velocities, the capital cost for equipment to extract incrementally more flow power at high velocities may not be “paid back” by the additional power generated. Rather than make assumptions as to appropriate rated velocities of TISEC devices, an iterative approach was chosen to determine the rated speed of the machine which yields the lowest cost of electricity at the particular site.

Seabed Composition: The seabed composition at the site has a major impact on the foundation design of the TISEC device. For a monopile foundation, the seabed composition determines the installation procedure (i.e. drilling and grouting or pile driving). The soil-

type will also impact the cost of the monopile. Typically, soft soils yield higher monopile cost than rock foundations.

Number of installed units: The number of TISEC devices deployed has a major influence on the resulting cost of energy. In general a larger number of units will result in lower cost of electricity due to economies of scale. There are several reasons for this which are outlined below:

- Infrastructure cost required to interconnect the devices to the electric grid can be shared and therefore their cost per unit of electricity produced is lower.
- Installation cost per turbine is lower because mobilization cost can be shared between multiple devices. It is also apparent that the installation of the first unit is more expensive than subsequent units as the installation contractor is able to increase their operational efficiency.
- Capital cost per turbine is lower because manufacturing of multiple devices will result in reduction of cost. The cost of manufactured steel as an example is very labor intensive. The cost of hot rolled steel plates as of July 2005 was \$650 per ton. The final product can however cost as much as \$4500 per manufactured ton of steel. With other words there is significant potential to reduce capital cost by introducing more efficient manufacturing processes and engineering a structure in such a way that it can be manufactured cost effectively. The capital cost for all other equipment and parts is very similar.

Device Reliability and O&M procedures: The device component reliability directly impacts to operation and maintenance cost of a device. It is important to understand that it is not only the component that needs to be replaced, but that the actual operation required to recover the component can dominate the cost. Additional cost of the failure is incurred by the downtime of the device and its inability to generate revenues by producing electricity. In order to determine these operational costs, the failure rate on a per component basis was estimated. Then operational procedures were outlined to replace these components and

carry out routine maintenance such as changing the oil. The access arrangement plays a critical role in determining what kind of maintenance strategy is pursued and the resulting total operation cost.

Insurance cost: The insurance cost can vary greatly depending on what the project risks are. While this is an area of uncertainty, especially considering the novelty of the technologies used and the likely lack of specific standards, it was assumed that a commercial farm will incur insurance costs similar to mature an offshore project which is typically at about 1.5% of installed cost. MCT is seeking to mitigate this problem by working with DNV (Det Norske Veritas), the ship classification society, to use existing marine standards in its design wherever possible [20].

The following table shows a cost breakdown of a commercial TISEC array at the deployment site.

Table 11 - Commercial Plant Cost Breakdown

	\$/kW	\$/Turbine	\$/Array	%	Note
Power Conversion System	\$660	\$472,665	\$30,250,532	29.2%	1
Structural Elements	\$845	\$605,062	\$38,723,977	37.4%	2
Subsea Cable Cost	\$18	\$12,699	\$812,705	0.8%	3
Turbine Installation	\$450	\$322,406	\$20,633,956	19.9%	4
Subsea Cable Installation	\$208	\$149,093	\$9,541,969	9.2%	5
Onshore Electric Grid Interconnection	\$76	\$54,688	\$3,500,000	3.4%	6
Total Installed Cost	\$2,258	\$1,616,612	\$103,463,138	100%	
O&M Cost	\$49	\$35,313	\$2,260,052	59.3%	7
Annual Insurance Cost	\$34	\$24,249	\$1,551,947	40.7%	8
Total annual O&M cost	\$83	\$59,562	\$3,811,999	100.0%	

1. Power conversion system cost includes all elements required to go from fluid power to electrical power suitable to interconnect to the TISEC array electrical collector system. As such it includes rotor blades, speed increaser, generator, grid synchronization and step-up transformer. The cost is based on a drive-train cost study by NREL [18] with necessary adjustments made such as marinization, gearing-ratio, rotational speed and turbine blade length. Progress ratios were used to account for cost changes at different production volumes.

2. Structural steel elements include all elements required to hold the turbine in place. In the case of MCT, this is the monopile and cross arm. In order to determine the amount of steel required, the manufacturer's data was scaled based on the estimated loads on the structure. Only principal loads based on the fluid velocity were considered and it was assumed that they are the driving factor. While this approach is well suited for a conceptual study, it must be stressed that other loading conditions such as wave loads, resonance conditions, pile driving forces, or seismic activity can significantly influence the design and will need to be taken into consideration in a detailed design phase.
3. Subsea cable cost includes the cable cost to collect the electricity from the turbines and bring the electricity to shore at a suitable location.
4. Turbine installation cost includes all cost components to install the turbines. Detailed models were developed to outline the deployment procedures using heavy offshore equipment such as crane barges, tugs, supply vessels, drilling equipment, mobilization charges and crew cost. Discussions with experienced contractors and offshore engineers were used to solidify costs.
5. Subsea cable installation cost includes, trenching, cable laying, and trench back-fill using a derrick barge. It also includes cable landing costs. If existing easements such as pipes or existing pier or bridge structures are in place, the cable can be landed on shore using these easements. If not, it was assumed that directional drilling is used to bring the cable to shore.
6. Onshore electrical grid interconnection includes all cost components required to bring the power to the next substation. Cost components required to build-out the capabilities of the substation or upgrade the transmission capacity of the electric grid are excluded from cost of energy calculations as these are born by the project but paid back as a wires charge over its life.

9. Cost of Electricity Assessments

To evaluate the economics of tidal in-stream power plants, three standard economic assessment methodologies have been used:

1. Utility Generator (UG),
2. Municipal Generator (MG)
3. Non-Utility Generator (NUG) or Independent Power Producer (IPP).

Taxable regulated utilities (independently owned utilities) are permitted to set electricity rates (i.e., collect revenue) that will cover operating costs and provide an opportunity to earn a reasonable rate of return on the property devoted to the business. This return must enable the UG to maintain its financial credit as well as to attract whatever capital may be required in the future for replacement, expansion and technological innovation and must be comparable to that earned by other businesses with corresponding risk.

Non taxable municipal utilities also set electricity rates that will cover operating costs, however, utility projects are financed by issuing tax-exempt bonds, enabling local governments to access some of the lowest interest rates available

Because the risks associated with private ownership are generally considered to be greater than utility ownership, the return on equity must be potentially higher in order to justify the investment. However, it is important to understand that there is no single right method to model an independently owned and operated NUG or IPP renewable power plant. Considerations such as an organization's access to capital, project risks, and power purchase and contract terms determine project risks and therefore the cost of money.

These regulated UG and MG methodologies are based on a levelized cost approach using both real (constant) and nominal (current) dollars with 2005 as the reference year and a 20-year book life. The purpose of these standard methodologies is to provide a consistent, verifiable and replicable basis for computing the cost of electricity (COE) of a tidal energy

generation project (i.e., a project to engineer, permit, procure, construct, operate and maintain a tidal energy power plant).

The NUG methodology is based on a cash flow analysis and projections of market electricity prices. This allows a NUG to estimate how quickly an initial investment is recovered and how returns change over time.

The results of this economic evaluation will help government policy makers determine the public benefit of investing public funds into building the experience base of tidal energy to transform the market to the point where private investment will take over and sustain the market. Such technology support is typically done through funding R&D and through incentives for the deployment of targeted renewable technologies.

If the economics of the notional commercial scale tidal in-stream power plant is favorable with respect to alternative renewable generation options, a case can be made for pursuing the development of tidal flow energy conversion technology. If, however, even with the most optimistic assumptions, the economics of a commercial size tidal flow power plant is not favorable and cannot economically compete with the alternatives, a case can be made for not pursuing tidal flow energy conversion technology development.

The methodology is described in detail in [2].

The yearly electrical energy produced and delivered to bus bar by the commercial TISEC plant described in sections 6 and 8 is estimated to be 120,000 MWh/year for an array consisting of sixty-four dual-rotor turbines. These turbines will, on average, extract 16MW of kinetic power from the tidal stream – 15% of the total kinetic energy in the flow at Pt. Evans. Turbines will be arranged in five rows of twelve to thirteen devices. The elements of cost and economics (in 2005\$) are:

- Total Plant Investment = \$103 million
- Annual O&M Cost = \$3.8 million

- Utility Generator (UG) Levelized Cost of Electricity (COE)⁷ = 9.0 (Real) – 10.6 (Nominal) cents/kWh with renewable energy incentives equal to those that the government provides for renewable wind energy technology
- Non Utility Generator (NUG) Levelized Cost of Electricity (IRR) = N/A
- Municipal Generator (MG) Levelized Cost of Electricity (COE) = 7.2 (Real) – 8.4 (Nominal) cents/kWh with renewable energy incentives equal to those that the government provides for renewable wind energy technology

The detailed worksheets including financial assumptions used to calculate these COEs and IRR are contained in Appendices (sections 13.4 through 13.6)

The COE for a Municipal Generator such as Tacoma Power is in the range of other renewable and non renewable energy supply options. Washington does not provide an internal rate of return (IRR) for a Non-Utility Generator as the avoided cost (average industrial wholesale rate is used as a proxy for avoided cost) is low (3.86 cents/kWh).

TISEC technology is very similar to wind technology and has benefited from the learning curve of wind technology, both on shore and off shore. Therefore, the entry point for a TISEC plant is much less than that of wind technology back in the late 1970s and early 1980s (i.e., over 20 cents/kWh). Additional cost reductions will certainly be realized through value engineering and economies of scale.

Except for the Minas Passage in Nova Scotia which clearly has the size to be considered central power, all other sites studied in the U.S. and Canada fall in between the definition of distributed generation (DG) and central power generation.

We use the term distributed generation (DG) or distributed resources (DR) to describe an electric generation plant located in close proximity to the load that it is supplying and is either connected to the electric grid at distribution level voltages or connected directly to the

⁷ For the 45.7 MW 20 year life plant, 10 years of PTC at 0.18 cents/kWh for a taxable entity, a REPI credit at \$0.015 cents/kWh for a non taxable MG and other assumptions documented in [2].

load. Examples of DG/DR (DR when some form of storage is included) are rooftop photovoltaic systems, natural gas micro turbines and small wind turbines. Large wind projects and traditional fossil and nuclear plants are examples of central generation where the electricity delivers power into the grid at transmission voltage levels.

DG types of systems traditionally find applications in niche markets because of unique market drivers such as:

- Delay or defer an upgrade to T&D infrastructure that would otherwise have been necessary to bring power generated away from a load center to that load center
- Voltage stability support
- Displace diesel fuel in off grid applications
- Satisfy local citizens desires to have control of their own power source

A realistic comparison to equitably evaluate the cost of deferring T&D expenses with the cost of installing DG/DR is complex and requires considering depreciation and tax benefits, property tax and insurance for both options, maintenance and fuel costs of operating the DG/DR and employing discounted cash flow methods. This comparison must be made on a case-by-case basis.

EPRI, in collaboration with DOER, NJBPU and CEC, and funded by NASEO, is studying political and financial mechanisms for win-win DG/DR solutions for both the distribution utility and the end user.

Economic assessments of a commercial scale tidal power plant and other renewable and non renewable energy systems were made. The current comparative costs of several different central power generation technologies are given in Table 12 below for 2010. Capital costs are given in \$/kW. They have wide ranges that depend on the size of the plant and other conditions such as environmental controls for coal and quality of the resource for geothermal. We are using generally accepted average numbers and ranges from EPRI sources [26].

Table 12 - COE for Alternative Energy Technologies: 2010

	Capacity Factor (%)	Capital Cost⁽¹⁾ (\$/kW)	COE (cents/kWh)	CO2 (lbs per MWh)
Tidal In-Stream	29-33	2,000	6-9	None
Wind (Class 3-6)	30-42	1,150	4.7-6.5	None
Solar Thermal Trough	33	3,300	18	None
Coal PC USC (2)	80	1,275	4.2	1760
NGCC ⁽³⁾ @ \$7/MM BTU)	80	480	6.4	860
IGCC ⁽²⁾ with CO2 capture	80	1,850	6.1	344 ⁽⁴⁾
Nuclear Evolutionary (ABWR)	85-90	1,660	4.7-5.0	None

Notes:

1. Costs in 2005\$
2. 600 MW capacity, Pittsburgh #8 coal
3. Based on GE 7F machine or equivalent by other vendors
4. Based on 85% removal

The fuel cost for coal and natural gas (NG) is the price of fuel (in \$ per Mbtu), times the heat rate (BTUs needed to generate a kWh of electricity – 10,000 for PC Coal, 9,000 for IGCC, 12,000 for Gas CT and 7,000 for NG CC), divided by 10,000.

Table 13 - Assumptions forming the Basis for COE for Alternative Energy Technologies

	Book Life/ Tax life)	Fed Tax Rate	State Tax Rate	Dep Sch	% Equity UG/ NUG/ Public	Equity Disc't Rate (Real) UG/NUG	% Debt UG/ NUG/ Public	Debt Disc't Rate (Real) UG/NUG/ Public	Inflation Rate
Tidal In-Stream	20/20	35	WA/0-	MACRS					3
Wind	30/ 20	35	6.5	MACRS	45/ 30/ 0	11.5/ 13/ N/A	55/ 70/ 100	6/5 8/ 4.5	2
Coal⁽²⁾ PC First of a Kind USC	30/ 20	35	6.5	ACRS	45/ 30/ 0	11.5/ 13/ N/A	55/ 70/ 100	6/5 8/ 4.5	2
IGCC⁽²⁾ GE Quench W/O CO2 capture	30/ 20	35	6.5	ACRS	45/ 30/ 00	11.5/ 13/ N/A	55/ 70/ 100	6/5 8/ 4.5	2
NGCC⁽³⁾ Advanced (@ \$7/MM Btu)	30/ 20	35	6.5	ACRS	45/ 30/ 00	11.5/ 13/ N/A	55/ 70/ 100	6/5 8/ 4.5	2
NGCC⁽³⁾ Advanced @ (\$5/MM Btu)	30/ 20	35	6.5	ACRS	45/ 30/ 0	11.5/ 13/ N/A	55/ 70/ 100	6/5 8/ 4.5	2
Nuclear - First of a kind (Gen IV)	30/ 20	35	6.5	ACRS	45/ 30/ 0	11.5/ 13/ N/A	55/ 70/ 100	6/5 8/ 4.5	2

10. Sensitivity Studies

The results reported thus far are for a single design case. Certain key parameters can have a significant impact on the cost of energy from a TISEC array. Among these are:

- Array size – economies of scale with larger arrays
- Availability – deployment of maturing technology
- Current velocities at site
- Financial assumptions – financing rates, renewable energy production credits

Cost of energy numbers presented are real costs for a municipal generator with assumptions discussed in Chapter 9. All costs are in 2005 USD. The base case for the commercial plant is 7.2 cents/kWh.

10.1. Array Size

This sensitivity has already been implicitly shown in the unit capital cost differences for pilot turbine versus commercial scale array. Figure 38 shows the sensitivity of cost of energy (COE) to the number of turbines installed⁸.

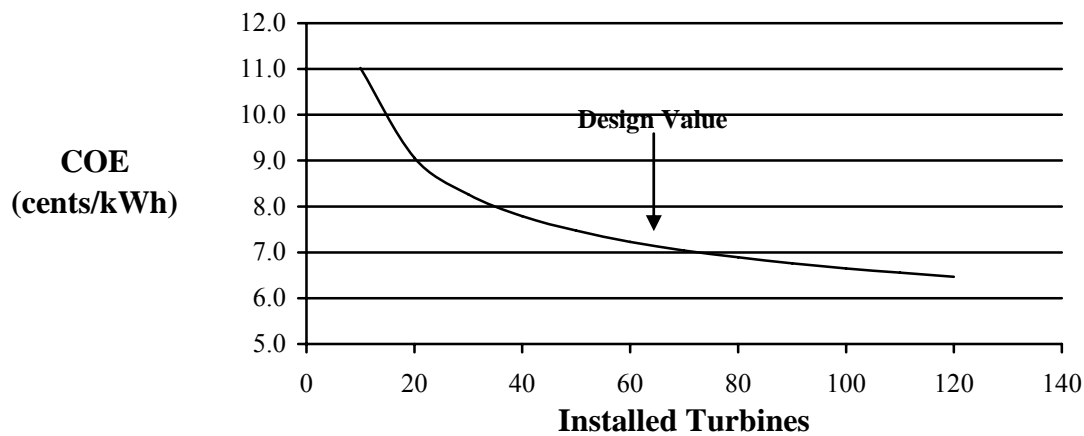


Figure 38 – Sensitivity of COE to number of turbines installed

Due to economies of scale (mobilization costs, increased manufacturing efficiency), the capital and operating costs for the array decrease with the number of installed turbines. The

⁸ Assumes 5 transect deployment of all turbines for purposes of calculating required subsea cable lengths.

sensitivity of the different elements of capital cost to the number of turbines installed is given in Figure 39.

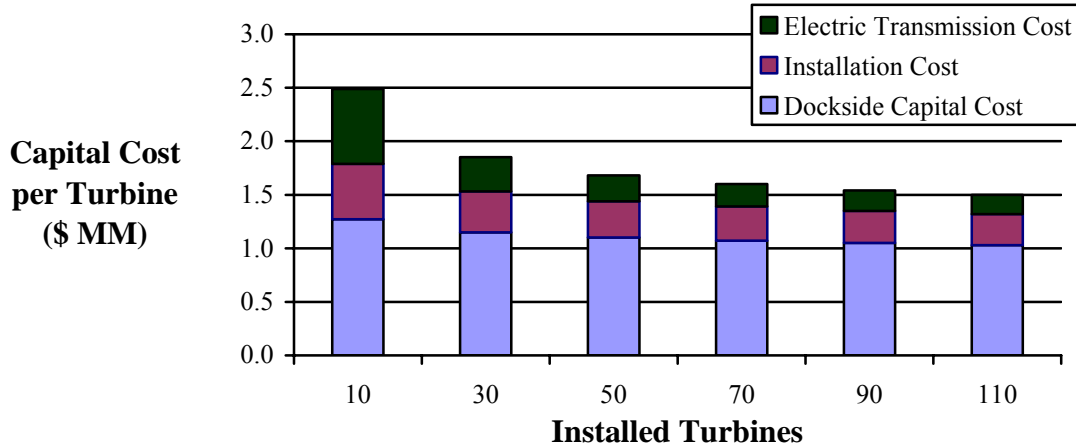


Figure 39 – Sensitivity of Capital Cost elements to number of installed turbines

Economies of scale due to decreasing capital cost occur in equipment, installation, and electrical interconnection. Installation and electrical transmission costs are nearly identical. Cost of energy decreases are not driven exclusively by scale in one particular area. Note that equipment costs dominate in all cases – even for small arrays. Annual O&M costs also decrease due to economies of scale (e.g. maintenance mobilization costs spread out over more turbines). The sensitivity of annual O&M costs to number of installed turbines is given in Figure 40.

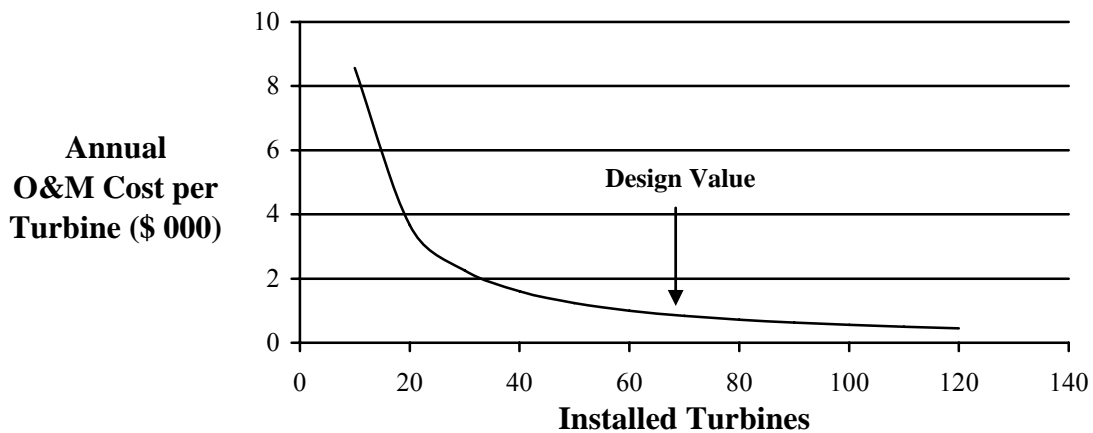


Figure 40 – Sensitivity of annual O&M cost to number of installed turbines

10.2. Array Availability

Given that tidal in-stream energy is an emerging industry and limited testing has been done to validate component reliability, the impact of array availability on cost of energy is key. If the availability is lower than anticipated, array output will be lower, but costs will be the same. This is shown in Figure 41, where all parameters aside from availability are held constant for the commercial array design.

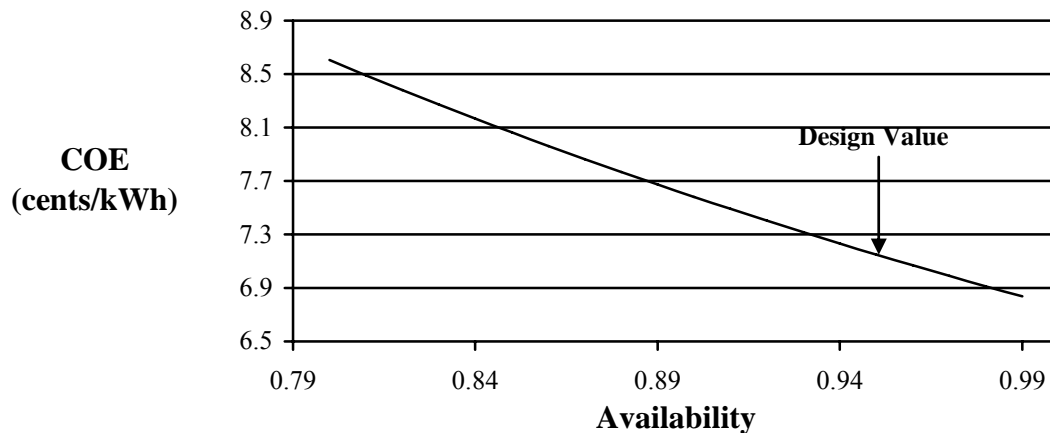


Figure 41 – Sensitivity of COE to array availability

If array availability is as low as 80%, the cost of energy will increase by a bit less than 1.5 cents/kWh (20% increase) compared to the assumed availability of 95%. This is a substantial increase and highlights the need of developers to verify expected component lifetimes and service schedules.

10.3. Current Velocity

One of the greatest unknowns in the array design is current velocity over the region of array deployment. The sensitivity of cost of energy to average current and power flux is shown in Figure 42 and Figure 43, where most other parameters are held constant for the commercial array design. Current velocity is modified by multiplying each velocity ‘bin’ by a constant value (e.g. 0.7). As a result, the statistical description of the velocity distribution is the same for all cases, only the mean value changes. As the maximum site velocity is varied, the rated speed of the turbine is allowed to vary to maintain the lowest possible cost of

energy. Note that average current velocity and power flux are not independent variables, the design point average current velocity corresponds to the design point average power flux.

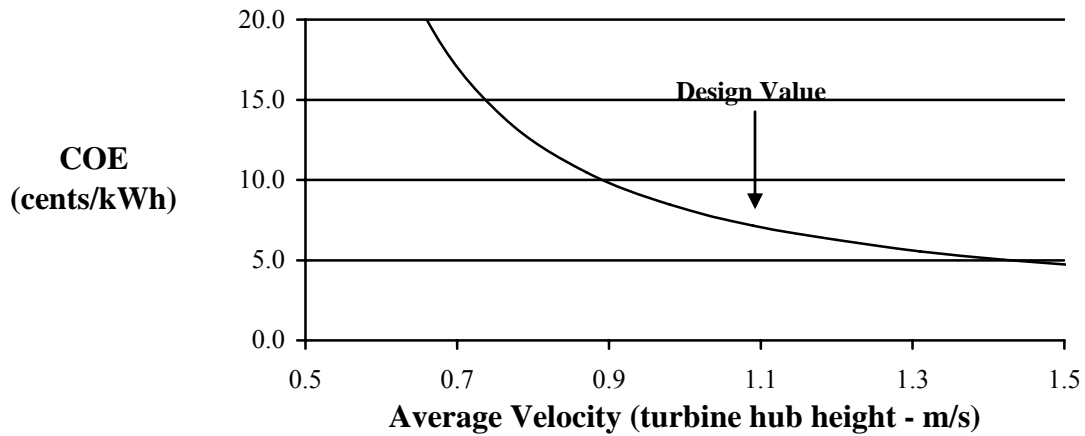


Figure 42 – Sensitivity of COE to average velocity

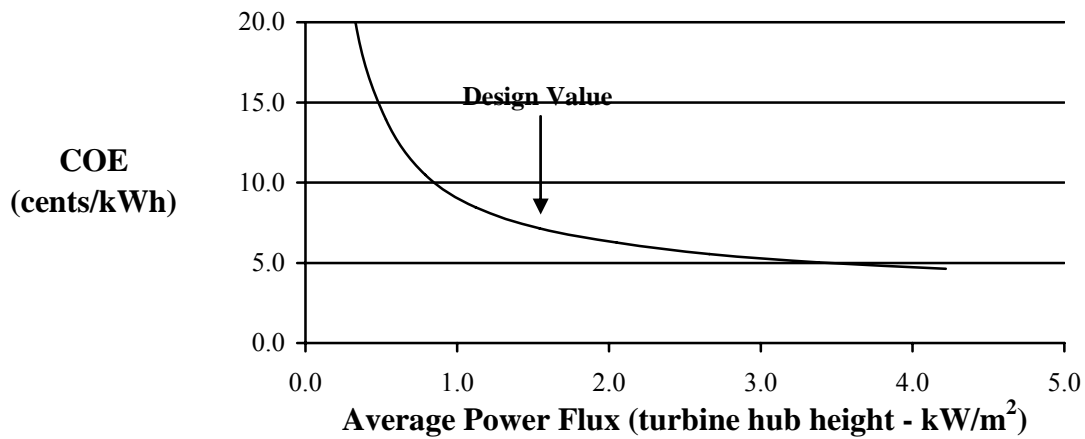


Figure 43 – Sensitivity of COE to average power flux

Clearly, the average velocity at the site has a significant effect on cost of energy, particularly if average current speeds are lower than expected. As average current speeds decrease below about 1 m/s, the cost of energy increases dramatically. Note that this result is dependent on the shape of the velocity distribution histogram and therefore, we can not broadly draw conclusions about the cost of energy at other sites from this analysis.

10.4. Design Velocity

During normal operation, peak loads on the support structure occur around rated current velocity. For current velocities in excess of rated, power extracted by the rotors is reduced by the pitching mechanism. Rotor thrust contributes to the majority of design stress (pile drag accounting for the remainder). As the rotor pitch changes above rated current velocity, the thrust coefficient on the rotors decreases. If the rotor pitch mechanism is functioning correctly, the support structure would experience similar stresses from rated velocity up to maximum site velocity. However, as discussed in Chapter 3, the design velocity for the turbine has been chosen to approximate “runaway” conditions – a pitch control failure in the maximum current existing at the site. If manufacturers are able to achieve sufficient operating experiences with their turbines to ensure that turbines will never operate in a “runaway” mode (e.g. incorporation of failsafe braking mechanism), then the design velocity could be set much closer to the rated velocity. Similar functionality is used in large wind-turbines to reduce loading conditions. The effect on the real cost of energy by bringing design and rated velocity to parity is shown in Figure 44.

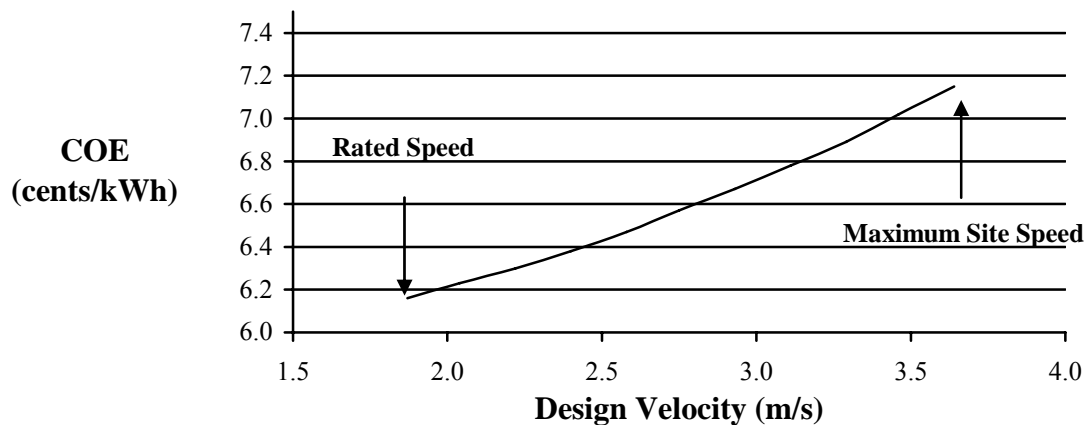


Figure 44 – Sensitivity of COE to design speed

10.5. Financial Assumptions

The effect of varying the fixed charge rate is shown in Figure 45. Fixed charge rate is varied by 30% from baseline value for the sensitivity.

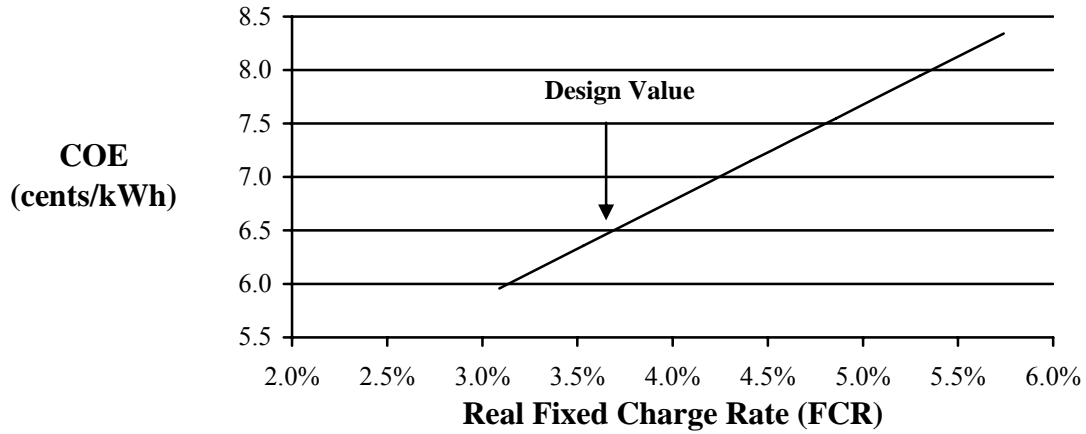


Figure 45 – Sensitivity of COE to debt financing rate

A sensitive assumption is the application of renewable energy production credits to the project. If a project is deemed ineligible for renewable production credits, or funds for such credits are not fully budgeted, COE increases by about 1.5 cents/kWh. Figure 46 shows the sensitivity of COE to production credits, with credits varied from 0% (no credits) to more credits than are currently assumed in the financial analysis.

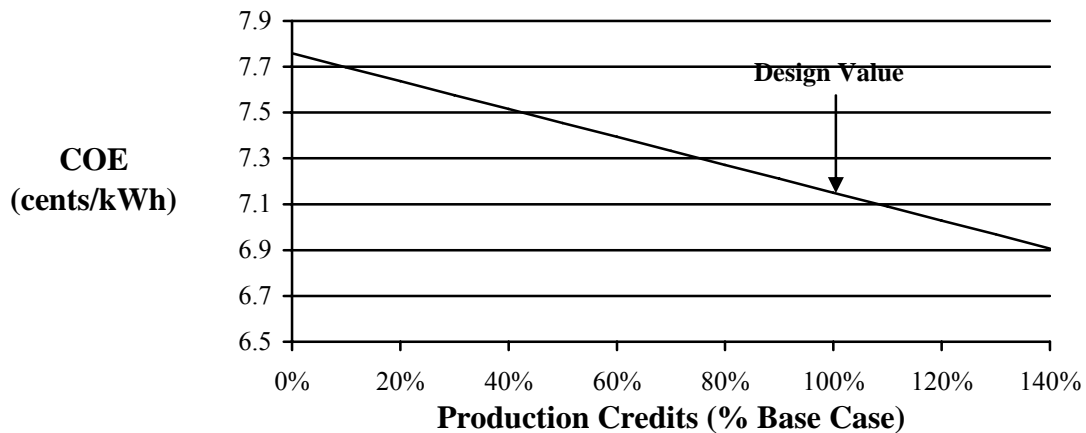


Figure 46 – Sensitivity of COE to production credits

11. Conclusions

For the single point commercial scale design chosen for feasibility assessment by EPRI in this study (based on the MCT SeaGen commercial prototype machine), Point Evans is a reasonably good location for the installation of a pilot tidal in-stream power plant. The predicted resource is strong, interconnection is easily managed, and the site is served by a major port facility in close proximity. The pilot will be surface-piercing and may fall inside the conventional shipping lanes for Tacoma Narrows. The purpose of the pilot is to demonstrate the potential for a commercial array, verify reliability, availability, low environmental impact and cost estimates, and generally build towards regulatory acceptance of an array of similar devices. Since the commercial plant will be fully submerged, the support structure for the commercial plant will vary from the pilot and may require some additional on-site testing prior to deployment.

11.1. Pilot In-Stream Tidal Power Plant

A pilot scale tidal power plant rated at 716kW, using an MCT commercial prototype SeaGen device would cost about \$4.2M to build and will produce an estimated 2010 MWh per year. This cost reflects only the capital needed to purchase a SeaGen unit, install it on site, and connect it to the grid. Therefore, it represents the installed capital cost required to evaluate and test a SeaGen TISEC system, but does not include detailed design, permitting and construction financing, yearly O&M or test and evaluation costs.

11.2. Commercial In-Stream Tidal Power Plant

A commercial scale tidal power plant at the same location was also evaluated to establish a base case from which economic comparisons to other renewable and non renewable energy systems could be made. The yearly electrical energy produced and delivered to bus bar is estimated to be 120,000 MWh/year for an array consisting of sixty-four dual-rotor turbines. These turbines will, on average, extract 16MW of kinetic power from the tidal stream – 15% of the total kinetic energy in the flow at Pt. Evans. The elements of cost and economics (in 2005\$) are:

- Total Plant Investment = \$103 million
- Annual O&M Cost = \$3.8 million
- Utility Generator (UG) Levelized Cost of Electricity (COE)⁹ = 9.0 (Real) – 10.6 (Nominal) cents/kWh with renewable energy incentives equal to those that the government provides for renewable wind energy technology
- Non Utility Generator (NUG) Levelized Cost of Electricity (IRR) = N/A due to low avoided cost of energy.
- Municipal Generator (MG) Levelized Cost of Electricity (COE) = 7.2 (Real) – 8.4 (Nominal) cents/kWh with renewable energy incentives equal to those that the government provides for renewable wind energy technology

Pt. Evans is a strong candidate site for the installation of a commercial tidal in-stream plant. The predicted resource is sufficient to generate a meaningful level of electric power (>10MW on average) with nearby high voltage transmission lines. Through the use of fully submerged next-generation devices, multiple turbine transects could be sited in the vicinity of Point Evans without impeding shipping traffic. Installation and operation of the array would occupy a relatively small area of the Narrows (<10%). For public safety reasons, it may be necessary to set up a recreation (e.g. diving) exclusion zone within this area.

Since the commercial array design incorporates features that are largely conceptual, there is significant economic and technical uncertainty in the deployment of a commercial array at Pt. Evans. If the cost and performance of a fully submerged design is in-line with SeaGen, then the results of this study show that an in-stream tidal power plant may provide favorable economics in terms of COE for a UG or MG in comparison to other locally available renewable energy production options. This is a technology worth pursuing.

11.3. Techno-economic Challenges

The cost for the first tidal plant leverages the learnings gained from wind energy. Rather than seeing a sharp reduction in unit cost in early production, a substantial decrease might

⁹ For the 45.7 MW 20 year life plant, 10 years of PTC at 0.18 cents/kWh for a taxable entity, a REPI credit at \$0.015 cents/kWh for a non taxable MG and other assumptions documented in [2].

require another 40,000 MW of installed capacity (double the end of 2004 wind production volume). Device manufacturers are pursuing value engineering and novel approaches to array-scale installations. The economic analysis presented in this report is based on first-generation device economics. The assumption implicit in this analysis is that while next-generation devices will enable turbine deployment at a wider range of sites (e.g. deep water) and with greater versatility (e.g. integrated lift without surface piercing pile) the cost of installing and operating next-generation turbines will be similar to first-generation devices. O&M costs are particularly uncertain since no tidal current turbine has been in service for extended periods of time. Assumptions regarding intervention frequencies, refit costs, and component lifetimes will not be completely borne out for at least a decade.

Sensitivities show that the cost of energy is highly dependent on the currents (and power flux) at the deployment site. This highlights the need for detailed site velocity measurements. Sensitivities also show that the cost of energy is sensitive to the number of turbines installed, since for larger arrays fixed mobilization costs are spread over a greater number of turbines. Therefore, a long-term phased installation of the array (e.g. 10 turbines/year for 6 years) would substantially increase the cost of energy for the entire project. A regulatory approach that requires a long-term phased installation plan to study the impact of turbine deployment should be discouraged if the project will not be compensated for the increased cost.

11.4. General Conclusions

In-stream tidal current energy shows significant promise for Tacoma Narrows and represents a way to make sustainable use of a local renewable resource without the visual distractions that delay so many other energy projects. The installation of a TISEC array at Tacoma Narrows would provide valuable benefits to the local economy and further reduce Puget Sound's dependence on environmentally problematic fossil energy resources.

In-stream tidal energy electricity generation is a new and emerging technology. Many important questions about the application of in stream tidal energy to electricity generation remain to be answered, such as:

- There is not a single in-stream power technology. There is a wide range of in stream tidal power technologies and power conversion machines which are currently under development. It is unclear at present what type of technology will yield optimal economics. Not all devices are equally suitable for deployment in all depths and currents.
- It is also unclear at present at which size these technologies will yield optimal economics. Tidal power devices are typically tuned to prevailing conditions at the deployment site. Wind turbines for example have grown in size from less than 100kW per unit to over 3MW in order to drive down cost.
- Will the predictability of in stream energy earn capacity payments for its ability to be dispatched for electricity generation?
- How soon will developers be ready to offer large-scale, fully submerged, deep water devices?
- Will the installed cost of in-stream tidal energy conversion devices realize their potential of being much less expensive per COE than solar or wind (because a tidal machine is converting a much more concentrated form of energy than a solar or wind machine)?
- Will the O&M cost of in-stream tidal energy conversion devices be as high as predicted in this study and remain much higher than the O&M cost of solar or wind (because of the more remote and harsher environment in which it operates and must be maintained)?
- Will the performance, reliability and cost projections be realized in practice once in stream tidal energy devices are deployed and tested?

And in particular for Tacoma Narrows:

- Detailed velocity measurements will be necessary around Point Evans prior to the deployment of even a pilot plant. Will the actual power flux experienced at the site meet the predictions made in this study? Sensitivity analysis clearly shows that if the power flux is much lower than expected, the cost of energy will increase substantially.

- How far out into the channel do the eddies around Point Evans extend? How close to Pt. Evans can turbines be sited without performance being degraded by eddies?
- Are assumptions related to turbine spacing (both laterally and downstream) reasonable? Could the array be packed even closer together (further reducing its footprint) without degrading individual turbine performance?
- Is extracting 15% of the kinetic energy resource a reasonable target? Could more of the resource be extracted without degrading the marine environment? If so, the cost of energy for the project could be further reduced by increasing the size of the array.
- What regulatory concerns need to be addressed prior to the granting of a permit for a commercial plant, and how can the pilot plant best address them? What additional regulatory concerns would need to be addressed for the commercial plant since aspects of the device will change from pilot to commercial?

In-stream tidal energy is a potential important energy source and should be evaluated for adding to Tacoma’s energy supply portfolio. A balanced and diversified portfolio of energy supply options is the foundation of a reliable and robust electric grid. TISEC offers an opportunity for Tacoma to expand its supply portfolio with a resource that is:

- Local – providing long-term energy security and keeping development dollars in the region
- Sustainable and green-house gas emission free
- Cost competitive compared to other options for expanding and balancing the region’s supply portfolio

Except for a few large tidal energy resource sites, such as Minas Passage, TISEC is in the grey zone between central and distributed power applications. Typical distributed generation (DG) motivations are:

- Delay transmission and distribution (T&D) infrastructure upgrade
- Provide voltage stability
- Displace diesel fuel in off-grid applications
- Provide guaranteed power

11.5. Recommendations

EPRI makes the following recommendations to the State of Washington Electricity stakeholders:

General

Build collaboration within the state of Washington and with other states and the Federal Government with common goals. In order to accelerate the growth and development of an ocean energy industry in the United States and to address and answer the many techno-economic challenges, a technology roadmap is needed which can most effectively be accomplished through leadership at the national level. The development of ocean energy technology and the deployment of this clean renewable energy technology would be greatly accelerated if the Federal Government was financially committed to supporting the development.

Join a working group to be established by EPRI (to be called “OceanFleet”) for existing and potential owners, buyers and developers of tidal in stream energy including the development of a permanent in stream tidal energy testing facility in the U.S. For this group EPRI will track and regularly report on:

- Potential funding sources
- In-stream tidal energy test and evaluation projects overseas (primarily in the UK) and in the U.S (Verdant RITE project, etc)
- Status and efforts of the permitting process for new in stream tidal projects
- Newly announced in-stream tidal energy devices

Encourage R&D at universities - potentially in partnership with pilot plant device developers.

Encourage State and Federal government support of RD&D

- Implement a national ocean tidal energy program at DOE

- Operate a national offshore ocean tidal energy test facility
- Promote development of industry standards
- Continue membership in the IEA Ocean Energy Program
- Clarify and streamline federal permitting processes
- Study provisions for tax incentives and subsidies
- Ensure that the public receives a fair return from the use of ocean tidal energy resources
- Ensure that development rights in state waters are allocated through a fair and transparent process that takes into account state, local, and public concerns

Pilot Demonstration

As Tacoma Power has already applied for and received a preliminary permit from FERC for a pilot feasibility demonstration plant at Pt. Evans in Tacoma Narrows, we recommend that Tacoma Power progress forward with other Phase II tasks including:

- Velocity profiling survey (ADCP with CFD). It is recommended that this consist of acoustic Doppler current profiling (ADCP) of the waters off Point Evans in a series of transects and data collection over a 14 day cycle at the selected pilot site. Computational fluid dynamic (CFD) modeling of tidal flows in the Narrows could help focus this work on the most promising areas, as well as identifying turbulent eddies which could degrade turbine performance.
- High resolution bottom bathymetry survey
- Geotechnical seabed survey
- Detailed engineering design using above data
- Environmental impact report
- Public outreach
- Implementation planning for Phase III – Construction
- Financing/incentive requirements study four Phase III and IV (Operation)

The replacement of the 115 kV line crossing towers at Tacoma Narrows represents a potential benefit to the project, since steps could be taken now to reduce the future cost of interconnection for the pilot or commercial plants.

Additionally, the project developer should look for opportunities to win public support for the demonstration. For example, as part of the onshore cable laying for interconnection, the primitive path to the beach at Point Evans could be improved to allow for greater public access. Pierce County Parks has an interest in extending the existing trail network to the beach. In addition to the recreational benefit, this would also allow the public easy access to view the turbine in operation.

Commercial Plant

In order to facilitate planning for a commercial plant, we recommend that Tacoma Power begin to develop and support intellectual capital related to the deployment of large arrays of TISEC devices. This would include activities such as:

- Modeling effect of turbines on current flows throughout Puget Sound. This would serve to justify the expected low impact of extraction. Additionally, this model could be used to understand the impact of further development of tidal energy upstream of Tacoma Narrows (e.g. Admiralty Inlet)
- Understanding array spacing limitations. In order to minimize the array footprint and take advantage of the most energetic water it will be imperative to cluster turbines as closely as possible without allowing the wake of one turbine to degrade the performance of another.

References

- 1 EPRI TP-001-NA Guidelines for Preliminary Estimation of Power Production
- 2 EPRI TP-002-NA Economic Assessment Methodology
- 3 EPRI TP-004-NA Survey and Characterization of TISEC Devices
- 4 EPRI TP-005-NA Methodology for Conceptual Level Design of TISEC Plant
- 5 Google Maps. <http://maps.google.com/>
- 6 Port of Tacoma. <http://www.portoftacoma.com/>
- 7 NOAA Tidal Current Predictions 2005. <http://www.tidesandcurrents.noaa.gov/>
- 8 NOAA Tidal Range Predictions 2005. <http://www.tidesandcurrents.noaa.gov/>
- 9 Roberts, Richard. Surface Sediments (series of 12 maps). University of Washington, Department of Oceanography. 1979
- 10 Paulson, Wayne. Personal Communication. Washington Department of Fish and Wildlife. 2006.
- 11 Dutch, Maggie. Personal Communication. Washington Department of Ecology. 2006.
- 12 McCready, Parker. Lecture to ME 426: Sustainable Energy. 2005.
- 13 Tacoma Narrows Bridge Geological Cross-Section. Washington Toll Bridge Authority. 1939.
- 14 Shannon and Wilson Inc., Preliminary Design Report for Tacoma Narrows Bridge. 2001.
- 15 Washington Coast Guard. Personal Communication. 2005.
- 16 Marine Exchange of Puget Sound. Personal Communication. 2005.
- 17 Long, E., M. Dutch, S. Aasen, K. Welch, Sediment Quality in Puget Sound: Year 3, Southern Puget Sound. 2002.
- 18 Bywaters G, John V, Lynch J, Mattila P, Norton G, Stowell J, Salata M, Labath O, Chertok A, Hablanian D. Northern Power Systems WindPACT Drive Train Alternative Design Study Report. 2005. Available through: <http://www.osti.gov/>
- 19 Gerwick, B. Construction of Marine and Offshore Structures. CRC Press, Boca Raton,

FL. 2000.

20 Marine Current Turbines. Personal Communication with Martin Wright and Peter Frankel. 2006.

21 Reller, Rob. Personal Communication. Manson Construction. Seattle, WA. 2006.

22 Quigg, John. Personal Communication. Quigg Brothers Construction. Aberdeen, WA. 2006.

23 Kellezi L, Hansen P, Static and dynamic analysis of an offshore mono-pile windmill foundation, Danish Geotechnical Institute, Lyngby, Denmark

24 Dawson, T. Simplified Analysis of Offshore Piles Under Cyclic Lateral Loads. *Ocean Engineering* 7;553-562. 1980.

25 Frankel, Peter. Marine Current Turbines. Personal Communication. 2005.

26 EPRI 2005 Summer Seminar. August 2005.

27 Myers L, Bahaj A. Simulated electrical power potential harnessed by marine current turbine arrays in the Alderney Race, *Renewable Energy* 30:11;1713-1731.

28 Bryden I, Couch J. ME1—marine energy extraction: tidal resource analysis, *Renewable Energy* 31:2;133-139.

12. Appendix

12.1. Validity of Pt. Evans Velocity Predictions for Commercial Array

While it is reasonable to conclude that the power output of a pilot TISEC device may be reasonably estimated by NOAA predictions for Pt. Evans, the extension of this assumption to the entire transect off Pt. Evans is questionable due to the variable bathymetry over length of transect.

In addition to NOAA predictions, a coarse computational fluid dynamics model of Tacoma Narrows (PRISM) was made available through the University of Washington. Due to the relative coarseness of the computational grid in Tacoma Narrows (only four grid elements across), a decision was made not to incorporate the output of this model into the prediction of current velocities. However, the results of the model are broadly in line with NOAA predictions, confirming the general validity of methods used in the feasibility study.

Depth averaged power and average depth for PRISM calculated flows in Tacoma Narrows are shown below. The coarseness of the grid should be obvious by comparison to the finer 10m bathymetry shown in Chapter 2.

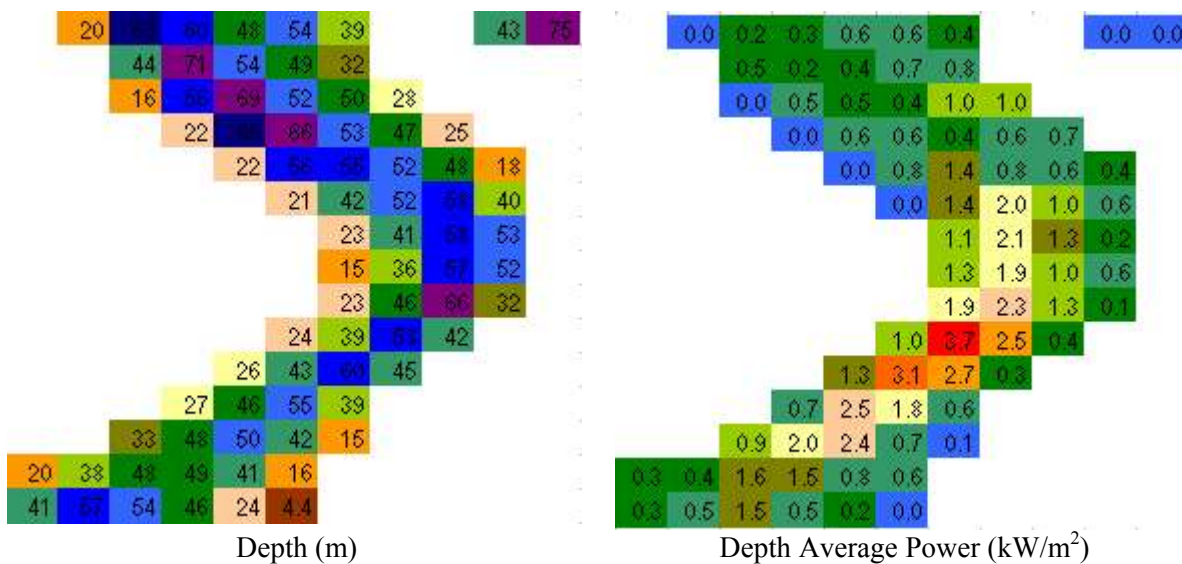


Figure 47 – PRISM Model Predictions for Tacoma Narrows

The PRISM model predicts a depth averaged power flux of 1.3 kW/m² in the vicinity of Pt.

Evans, in comparison to 1.7 kW/m^2 for the NOAA current station. Power flux is lower on the east side of the channel than the west. Peak power flux is predicted to occur a bit further south, closer to the bridge transect. Since the coarseness of the grid omits many of the significant bathymetric features of the Narrows, the validity of the output to this project is questionable. These predictions also do not show a known high power point on the east side of the channel near Point Defiance.

Due to the coarseness of the grid, channel cross-sectional area varies considerably from the real channel and so channel power as calculated by the model can not be used *a priori*. Since the primary purpose of the model is hindcasting circulation in Puget Sound, the model has better resolution near the surface to incorporate wind effects. Therefore, the model also can not be used to verify the $1/10^{\text{th}}$ velocity profile assumed for this study. Follow-on work for this project could involve refinement to the model in Tacoma Narrows for improved resolution and understanding of the impact of deploying a commercial turbine array. It is worth noting that any refinement to the model will be highly computationally and storage intensive. For example, the coarse output shown above involves averaging of one year of data over the fifteen depth levels. One year of current and velocity data for even this relatively small area requires almost 2 GB of storage.

Conversations with Devine Tarbell and a driver with the department of fish and wildlife [10] indicate that flows may be stronger on the east side of the channel than at the reference station. A footnote in the NOAA tables contradicts this assertion and at the northern end of the channel, the deeper water region on the west side of the channel has a much lower power flux (Figure 2). Without the use of ADCP measurements, supplemented by CFD modeling, a final determination of flow velocity on the east side of the Pt. Evans transects is mere guesswork. As such, the assumption that surface velocity is uniform across the entire channel is no worse than any other assumption.

12.2. Irrelevance of Flow Decay Concerns

A concern established by some other researchers, particularly Bahaj and Myers [27] is that the power available in a tidal stream is reduced for each subsequent transect of turbines.

Their results point to a substantial reduction in flow power, and degraded array performance, for arrays with more than a few transects.

This analysis is, however, in error as it violates mass conservation for tidal channels by assuming that the cross-sectional area of the channel is constant along the entire array. If the velocity of the flow is decreasing over each transect, then the area of the channel would have to increase to maintain conservation of mass.

However, the fuller picture is considerably more counter-intuitive. The total power in a tidal stream is the summation of the kinetic energy due to its velocity and the potential energy due to its height. For representative tidal channels, if the height of the water was to increase to satisfy mass conservation, the potential energy of the stream would also increase. In fact, this increase in potential energy would actually exceed the decrease of kinetic energy due to the presence of turbines and the total power in the channel would increase after each transect. Since this rationale violates conservation of energy it is also, clearly, incorrect. In order to satisfy both conservation of mass and energy, after each transect, the height of the water decreases and velocity *increases*. The net effect is a decrease in channel power, but from a kinetic energy standpoint, the presence of upstream turbines actually should improve the performance of those downstream. This effect is described in detail for an ideal channel in Bryden and Couch [28].

However, without detailed information about cross-channel flow both upstream and downstream of the proposed turbine array it is not possible to model the potential performance enhancement. As a result, any such transect-to-transect enhancement is omitted from the model. However, it would appear that concerns related to flow degradation have little scientific basis.

12.3. Hub-height Velocity Approximation

In order to simplify calculations, it has been assumed that the power flux over the swept area of the turbine may be approximated by the power flux at the hub height. Assuming the

velocity profile in the channel varies with a $1/10^{\text{th}}$ power law, the average power flux over the area of the turbine is given by the following integral:

$$\bar{P} = \frac{\int_0^{2\pi R} \int_0^1 \frac{1}{2} \rho u_o^3 \left(\frac{r \sin \theta + z_{hub}}{z_o} \right)^{3/10} r dr d\theta}{\int_0^{2\pi R} \int_0^1 r dr d\theta}$$

where P is the average power flux, R is the radius of the turbine, u_o is the surface current velocity, z_o is the depth of the water, and z_{hub} is the hub height.

This integral is not readily evaluated by analytical methods, but may be approached numerically. This is done by approximating the rotor as a series of rectangles with height Δz and width Δx . The power flux for the rectangles is calculated, and an area-weighted average taken to find the average power flux over the rotor. A representation of this method is shown in Figure 48.

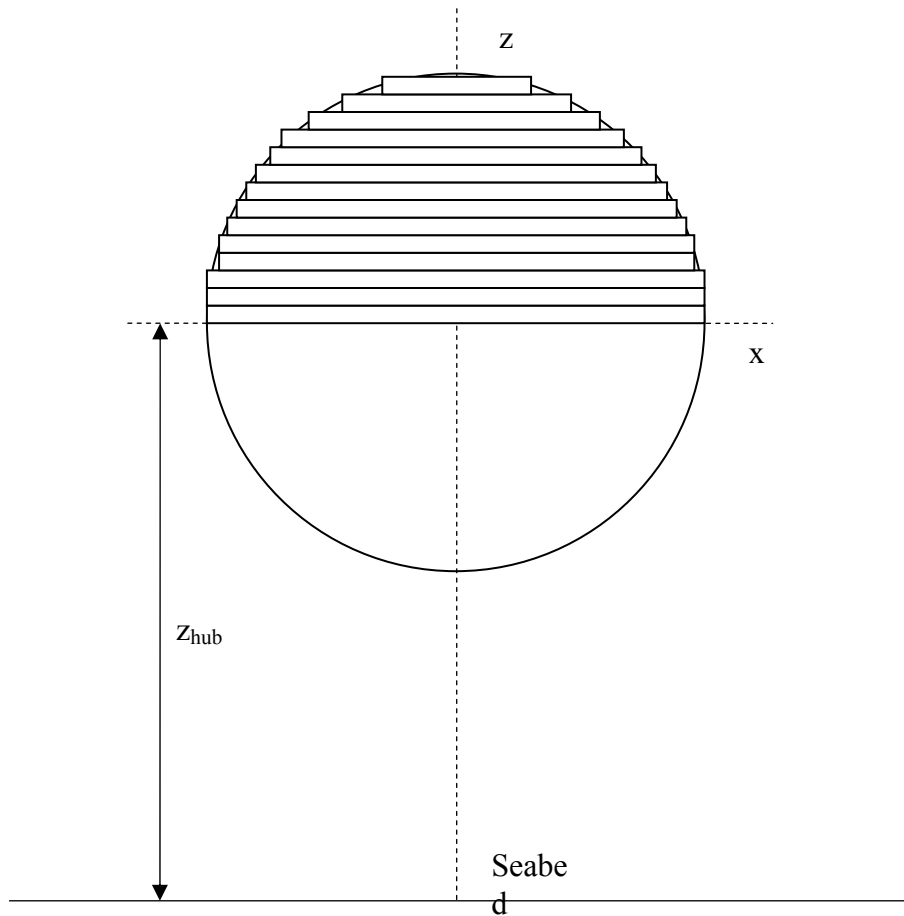


Figure 48 – Representative Numerical Integration

The result of this calculation is independent of water depth and velocity, but is dependent on hub height above the seabed. The variance from midpoint power flux (defined as $\Delta P/P_{\text{hub height}}$) is tabulated in Table 13.

Table 13 – Approximation Variance as Function of Hub Height

Hub Height (m)	Variance
10	-2.7%
15	-1.0%
20	-0.6%
30	-0.3%

A hub height of 17m (as assumed for the purposes of this feasibility study) introduces an error of -0.8% — that is, the actual power extracted by a turbine when approximating the power flux as the midpoint power flux is approximately 1% less than would be extracted by

a turbine operating in water with a $1/10^{\text{th}}$ power velocity profile. For the purposes of a feasibility study, this approximation is reasonable.

12.4. Utility Generator Cost of Electricity Worksheet

INSTRUCTIONS					
		Indicates Input Cell (either input or use default values)			
		Indicates a Calculated Cell (do not input any values)			
Sheet 1.	TPC/TPI (Total Plant Cost/Total Plant Investment)				
	a)	Enter Component Unit Cost and No. of Units per System			
	b)	Worksheet sums component costs to get TPC			
	c)	Adds the value of the construction loan payments to get TPI			
	d)	Enter Annual O&M Type including annualized overhaul and refit cost			
	e)	Worksheet Calculates insurance cost and Total Annual O&M Cost			
Sheet 2.	Assumptions (Financial)				
	a)	Enter project and financial assumptions or leave default values			
Sheet 3.	NPV (Net Present Value)				
	A	Gross Book Value = TPI			
	B	Annual Book Depreciation = Gross Book Value/Book Life			
	C	Cumulative Depreciation			
	D	MACRS 5 Year Depreciation Tax Schedule Assumption			
	E	Deferred Taxes = (Gross Book Value X MACRS Rate - Annual Book Depreciation) X Debt Financing Rate			
	F	Net Book Value = Previous Year Net Book Value - Annual Book Depreciation - Deferred Tax for that Year			
Sheet 4.	CRR (Capital Revenue Requirements)				
	A	Net Book Value for Column F of NPV Worksheet			
	B	Common Equity = Net Book X Common Equity Financing Share X Common Equity Financing Rate			
	C	Preferred Equity = Net Book X Preferred Equity Financing Share X Preferred Equity Financing Rate			
	D	Debt = Net Book X Debt Financing Share X Debt Financing Rate			
	E	Annual Book Depreciation = Gross Book Value/Book Life			
	F	Income Taxes = (Return on Common Equity + Return of Preferred Equity - Interest on Debt + Deferred Taxes) X (Comp Tax Rate/(1-Comp Tax Rate))			
	G	Property Taxes and Insurance Expense =			
	H	Calculates Investment and Production Tax Credit Revenues			
	I	Capital Revenue Req'ts = Sum of Columns B through G			
Sheet 5.	FCR (Fixed Charge Rate)				
	A	Nominal Rates Capital Revenue Req'ts from Column H of Previous Worksheet			
	B	Nominal Rate Present Worth Factor = $1 / (1 + \text{After Tax Discount Rate})$			
	C	Nominal Rate Product of Columns A and B = $A * B$			
	D	Real Rates Capital Revenue Req'ts from Column H of Previous Worksheet			
	E	Real Rates Present Worth Factor = $1 / (1 + \text{After Tax Discount Rate} - \text{Inflation Rate})$			
	F	Real Rates Product of Columns A and B = $A * B$			
Sheet 6.	Calculates COE (Cost of Electricity)				
		$COE = ((TPI * FCR) + AO\&M) / AEP$			
		In other words...The Cost of Electricity =			
		The Sum of the Levelized Plant Investment + Annual O&M Cost including Levelized Overhaul and Replacement Cost Divided by the Annual Electric Energy Consumption			

TOTAL PLANT COST (TPC) - 2005\$

TPC Component	Unit	Unit Cost	Total Cost (2005\$)
Procurement			
Power Conversion System	64	\$472,665	\$30,250,532
Structural Elements	64	\$605,062	\$38,723,977
Subsea Cables	Lot	\$812,705	\$812,705
Turbine Installation	64	\$322,406	\$20,633,956
Subsea Cable Installation	Lot	\$9,541,969	\$9,541,969
Onshore Grid Interconnection	Lot	\$3,500,000	\$3,500,000
TOTAL			\$103,463,138

TOTAL PLANT INVESTMENT (TPI) - 2005\$

End of Year	Total Cash Expended TPC (2005\$)	Before Tax Construction Loan Cost at Debt Financing Rate	2005 Value of Construction Loan Payments	TOTAL PLANT INVESTMENT 2005\$
2007	\$51,731,569	\$3,879,868	\$3,163,220	\$54,894,790
2008	\$51,731,569	\$3,879,868	\$2,856,181	\$54,587,750
Total	\$103,463,138	\$7,759,735	\$6,019,401	\$109,482,540

ANNUAL OPERATING AND MAINTENANCE COST (AO&M) - 2005\$

Costs	Yrly Cost	Amount
Labor and Parts	\$2,260,052	\$2,260,052
Insurance (1.5% of TPC)	\$1,551,947	\$1,551,947
Total		\$3,811,999

FINANCIAL ASSUMPTIONS

(default assumptions in pink background - without line numbers are calculated values)

	Rated Plant Capacity ©	45.81772391	MW
	Annual Electric Energy Production (AEP)	120,007	MWeh/yr
	Therefore, Capacity Factor	29.9	%
1	Year Constant Dollars	2005	Year
2	Construction Start	2007	Year
3	Construction Period	2	Year
	Federal Tax Rate	35	%
5	State	Washington	▼
6	Generator	Utility Generator	▼
	State Tax Rate	-	%
	Composite Tax Rate (t)	0.35000	
	t/(1-t)	0.53846	
7	Book Life	20	Years
	Construction Financing Rate	7.5	%
	Common Equity Financing Share	52	%
	Preferred Equity Financing Share	13	%
	Debt Financing Share	35	%
	Common Equity Financing Rate	13.0	%
	Preferred Equity Financing Rate	10.5	%
	Debt Financing Rate	7.5	%
	Nominal Discount Rate Before-Tax	10.75	%
	Nominal Discount Rate After-Tax	9.83	%
8	Inflation Rate = 3%	3	%
	Real Discount Rate Before-Tax	7.52	%
	Real Discount Rate After-Tax	6.63	%
	Federal Investment Tax Credit (1)	0	
	Federal Production Tax Credit (2)	0.018	
	Federal REPI (3)	0.000	
	State Investment Tax Credit	0	\$
	State Investment Tax Credit Limit	None	
	Renewable Energy Certificate (4)	0.000	\$/kWh

Notes

- 1 1st year only - cannot take Fed ITC and PTC
- 2 \$/kWh for 1st 10 years with escalation (assumed 3% per yr)
- 3 \$/kWh for 1st 10 years with escalation (assumed 3% per yr)
- 4 \$/kWh for entire plant life with escalation (assumed 3% per yr)

NET PRESENT VALUE (NPV) - 2005 \$

TPI = **\$109,482,540**

Year End	Gross Book Value A	Book Depreciation		Renewable Resource MACRS Tax Depreciation Schedule D	Deferred Taxes E	Net Book Value F
		Annual B	Accumulated C			
2008	109,482,540					109,482,540
2009	109,482,540	5,474,127	5,474,127	0.2000	5,747,833	98,260,579
2010	109,482,540	5,474,127	10,948,254	0.3200	10,346,100	82,440,352
2011	109,482,540	5,474,127	16,422,381	0.1920	5,441,282	71,524,943
2012	109,482,540	5,474,127	21,896,508	0.1152	2,498,392	63,552,425
2013	109,482,540	5,474,127	27,370,635	0.1152	2,498,392	55,579,906
2014	109,482,540	5,474,127	32,844,762	0.0576	291,224	49,814,556
2015	109,482,540	5,474,127	38,318,889	0.0000	-1,915,944	46,256,373
2016	109,482,540	5,474,127	43,793,016	0.0000	-1,915,944	42,698,190
2017	109,482,540	5,474,127	49,267,143	0.0000	-1,915,944	39,140,008
2018	109,482,540	5,474,127	54,741,270	0.0000	-1,915,944	35,581,825
2019	109,482,540	5,474,127	60,215,397	0.0000	-1,915,944	32,023,643
2020	109,482,540	5,474,127	65,689,524	0.0000	-1,915,944	28,465,460
2021	109,482,540	5,474,127	71,163,651	0.0000	-1,915,944	24,907,278
2022	109,482,540	5,474,127	76,637,778	0.0000	-1,915,944	21,349,095
2023	109,482,540	5,474,127	82,111,905	0.0000	-1,915,944	17,790,913
2024	109,482,540	5,474,127	87,586,032	0.0000	-1,915,944	14,232,730
2025	109,482,540	5,474,127	93,060,159	0.0000	-1,915,944	10,674,548
2026	109,482,540	5,474,127	98,534,286	0.0000	-1,915,944	7,116,365
2027	109,482,540	5,474,127	104,008,413	0.0000	-1,915,944	3,558,183
2028	109,482,540	5,474,127	109,482,540	0.0000	-1,915,944	0

CAPITAL REVENUE REQUIREMENTS 2005\$

TPI = \$109,482,540

End of Year	Net Book	Returns to Equity Common	Returns to Equity Pref	Interest on Debt	Book Dep	Income Tax on Equity Return	Fed PTC and REC	Capital Revenue Req'ts
	A	B	C	D	E	F	H	I
2009	98,260,579	6,642,415	1,341,257	2,579,340	5,474,127	6,005,012	2,160,126	19,882,025
2010	82,440,352	5,572,968	1,125,311	2,164,059	5,474,127	8,012,480	2,160,126	20,188,818
2011	71,524,943	4,835,086	976,315	1,877,530	5,474,127	5,048,160	2,160,126	16,051,092
2012	63,552,425	4,296,144	867,491	1,668,251	5,474,127	3,227,417	2,160,126	13,373,304
2013	55,579,906	3,757,202	758,666	1,458,973	5,474,127	2,991,308	2,160,126	12,280,149
2014	49,814,556	3,367,464	679,969	1,307,632	5,474,127	1,632,090	2,160,126	10,301,155
2015	46,256,373	3,126,931	631,399	1,214,230	5,474,127	338,238	2,160,126	8,624,799
2016	42,698,190	2,886,398	582,830	1,120,827	5,474,127	232,861	2,160,126	8,136,917
2017	39,140,008	2,645,865	534,261	1,027,425	5,474,127	127,484	2,160,126	7,649,036
2018	35,581,825	2,405,331	485,692	934,023	5,474,127	22,107	2,160,126	7,161,154
2019	32,023,643	2,164,798	437,123	840,621	5,474,127	-83,270	0	8,833,399
2020	28,465,460	1,924,265	388,554	747,218	5,474,127	-188,647	0	8,345,517
2021	24,907,278	1,683,732	339,984	653,816	5,474,127	-294,024	0	7,857,636
2022	21,349,095	1,443,199	291,415	560,414	5,474,127	-399,401	0	7,369,754
2023	17,790,913	1,202,666	242,846	467,011	5,474,127	-504,778	0	6,881,872
2024	14,232,730	962,133	194,277	373,609	5,474,127	-610,155	0	6,393,991
2025	10,674,548	721,599	145,708	280,207	5,474,127	-715,532	0	5,906,109
2026	7,116,365	481,066	97,138	186,805	5,474,127	-820,909	0	5,418,228
2027	3,558,183	240,533	48,569	93,402	5,474,127	-926,285	0	4,930,346
2028	0	0	0	0	5,474,127	-1,031,662	0	4,442,465
Sum of Annual Capital Revenue Requirements								190,027,765

FIXED CHARGE RATE (FCR) - NOMINAL AND REAL LEVELIZED - 2005\$

TPI = \$109,482,540

End of Year	Capital Revenue Req'ts Nominal A	Present Worth Factor Nominal B	Product of Columns A and B C	Capital Revenue Req'ts Real D	Present Worth Factor Real E	Product of Columns D and E F
2009	19,882,025	0.6872	13,663,341	17,664,922	0.7735	13,663,341
2010	20,188,818	0.6257	12,632,266	17,415,052	0.7254	12,632,266
2011	16,051,092	0.5697	9,144,270	13,442,537	0.6802	9,144,270
2012	13,373,304	0.5187	6,936,769	10,873,720	0.6379	6,936,769
2013	12,280,149	0.4723	5,799,576	9,694,063	0.5983	5,799,576
2014	10,301,155	0.4300	4,429,479	7,894,978	0.5611	4,429,479
2015	8,624,799	0.3915	3,376,678	6,417,660	0.5262	3,376,678
2016	8,136,917	0.3565	2,900,512	5,878,282	0.4934	2,900,512
2017	7,649,036	0.3246	2,482,536	5,364,880	0.4627	2,482,536
2018	7,161,154	0.2955	2,116,148	4,876,397	0.4340	2,116,148
2019	8,833,399	0.2691	2,376,648	5,839,917	0.4070	2,376,648
2020	8,345,517	0.2450	2,044,393	5,356,670	0.3817	2,044,393
2021	7,857,636	0.2230	1,752,577	4,896,619	0.3579	1,752,577
2022	7,369,754	0.2031	1,496,622	4,458,822	0.3357	1,496,622
2023	6,881,872	0.1849	1,272,448	4,042,375	0.3148	1,272,448
2024	6,393,991	0.1683	1,076,414	3,646,404	0.2952	1,076,414
2025	5,906,109	0.1533	905,280	3,270,070	0.2768	905,280
2026	5,418,228	0.1396	756,158	2,912,564	0.2596	756,158
2027	4,930,346	0.1271	626,480	2,573,111	0.2435	626,480
2028	4,442,465	0.1157	513,958	2,250,960	0.2283	513,958
	190,027,765		76,302,552	138,770,001		76,302,552

	Nominal \$	Real \$
1. The present value is at the beginning of 2006 and results from the sum of the products of the annual present value factors times the annual requirements	76,302,552	76,302,552
2. Escalation Rate	3%	3%
3. After Tax Discount Rate = i	9.83%	6.63%
4. Capital recovery factor value = $i(1+i)^n / (1+i)^n - 1$ where book life = n and discount rate = i	0.116109617	0.091712273
5. The levelized annual charges (end of year) = Present Value (Item 1) * Capital Recovery Factor (Item 4)	8,859,460	6,997,881
6. Booked Cost	109,482,540	109,482,540
7. The levelized annual fixed charge rate (levelized annual charges divided by the booked cost)	0.0809	0.0639

LEVELIZED COST OF ELECTRICITY CALCULATION - Utility Generator - 2005\$

$COE = ((TPI * FCR) + AO\&M) / AEP$

In other words...

The Cost of Electricity =

The Sum of the Levelized Plant Investment + Annual O&M Cost including Levelized Overhaul and Replacement Cost
Divided by the Annual Electric Energy Consumption

NOMINAL RATES

	<u>Value</u>	<u>Units</u>	<u>From</u>
TPI	\$109,482,540	\$	From TPI
FCR	8.09%	%	From FCR
AO&M	\$3,811,999	\$	From AO&M
AEP =	120,007	MWeh/yr	From Assumptions
COE - TPI X FCR	7.38	cents/kWh	
COE - AO&M	3.18	cents/kWh	
COE	\$0.1056	\$/kWh	Calculated
COE	10.56	cents/kWh	Calculated

REAL RATES

TPI	\$109,482,540	\$	From TPI
FCR	6.39%	%	From FCR
AO&M	\$3,811,999	\$	From AO&M
AEP =	120,007	MWeh/yr	From Assumptions
COE - TPI X FCR	5.83	cents/kWh	
COE - AO&M	3.18	cents/kWh	
COE	\$0.0901	\$/kWh	Calculated
COE	9.01	cents/kWh	Calculated

12.5. Non Utility Generator Internal Rate of Return Worksheet

INSTRUCTIONS					
Fill in first four worksheets (or use default values) - the last two worksheets are automatically calculated. Refer to EPRI Economic Methodology Report 002					
		Indicates Input Cell (either input or use default values)			
		Indicates a Calculated Cell (do not input any values)			
Sheet 1. Total Plant Cost/Total Plant Investment (TPC/TPI) - 2005\$					
	1	Enter Component Unit Cost and No. of Units per System			
	2	Worksheet sums component costs to get TPC			
	3	Worksheet adds the value of the construction loan payments to get TPI			
Sheet 2. AO&M (Annual Operation and Maintenance Cost) - 2005\$					
	1	Enter Labor Hrs and Cost by O&M Type)			
	2	Enter Parts and Supplies Cost by O&M Type)			
	3	Worksheet Calculates Total Annual O&M Cost			
Sheet 3. O&R (Overhaul and Replacement Cost) - 2005\$					
	1	Enter Year of Cost and O&R Cost per Item			
	2	Worksheet calculates inflation to the year of the cost of the O&R			
Sheet 4. Assumptions (Project, Financial and Others)					
	1	Enter project, financial and other assumptions or leave default values			
Sheet 5. Income Statement - Assuming no capacity factor income - Current \$					
	1	2008 1st Year Energy payments = AEP X 2005 wholesale price X 97.18% (to adjust price from 2005 to 2008 (an 2.82% decline) X Inflation from 2005 to 2008			
		2009-2011 Energy payments = AEP X Previous Year Elec Price X Annual Price de-escalation of -1.42% X Inflation			
		2012-2025 Energy payments = AEP X Previous Year Elec Price X 0.72% Price escalation X Inflation			
	2	Calculates State Investment and Production tax credit			
	3	Calculates Federal Investment and Production Tax Credit			
	4	Scheduled O&M from TPC worksheet with inflation			
	5	Scheduled O&R from TPC worksheet with inflation			
	8	Earnings before EBITDA = total revenues less total operating costs			
	9	Tax Depreciation = Assumed MACRS rate X TPI			
	10	Interest paid = Annual interest given assumed debt interest rate and life of loan			
	11	Taxable earnings = Tax Depreciation + Interest Paid			
	12	State Tax = Taxable Earnings x state tax rate			
	13	Federal Tax = (Taxable earnings - State Tax) X Federal tax rate			
	14	Total Tax Obligation = Total State + Federal Tax			
Sheet 6. Cash Flow Statement - Current \$					
	1	EBITDA			
	2	Taxes Paid			
	3	Cash Flow From Operations = EBITDA - Taxes Paid			
	4	Debt Service = Principal + Interest paid on the debt loan			
	5	Net Cash Flow after Tax			
		Year of Start of Ops minus 1 = Equity amount			
		Year of Start of Ops = Cash flow from ops - debt service			
		Year of Start of Ops Plus 1 to N = Cash flow from ops - debt service			
	6	Cum Net Cash Flow After Taxes = previous year net cash flow + current year net cash flow			
	7	Cum IRR on net cash Flow After Taxes = discount rate that sets the present worth of the net cash flows over the book life equal to the equity investment at the commercial operations			

TOTAL PLANT COST (TPC) - 2005\$

TPC Component	Unit	Unit Cost	Total Cost (2005\$)	Notes and Assumptions
Procurement				
Power Conversion System	64	\$472,665	\$30,250,560	
Structural Elements	64	\$605,062	\$38,723,968	
Subsea Cables	Lot		\$812,705	
Turbine Installation	64	\$322,406	\$20,633,984	
Subsea Cable Installation	Lot		\$9,541,969	
Onshore Grid Interconnection	Lot		\$3,500,000	
TOTAL			\$103,463,186	

TOTAL PLANT INVESTMENT (TPI) - 2005 \$

End of Year	Total Cash Expended TPC (\$2005)	Before Tax Construction Loan Cost at Debt Financing Rate	2005 Value of Construction Loan Payments	TOTAL PLANT INVESTMENT (TPC + Loan Value) (\$2005)
2006	\$50,068,672	\$3,755,150	\$3,061,539	\$53,130,211
2007	\$50,068,672	\$3,755,150	\$2,764,370	\$52,833,042
Total	\$100,137,344	\$7,510,301	\$5,825,909	\$105,963,253

ANNUAL OPERATING AND MAINTENANCE COST (AO&M) - 2005\$

Costs	Yrly Cost	Amount
Labor and Parts	\$2,260,052	\$2,260,052
Insurance (1.5% of TPC)	\$1,551,948	\$1,551,948
Total		\$3,812,000

FINANCIAL ASSUMPTIONS

(default assumptions in pink background - without line numbers are calculated values)

1	Rated Plant Capacity ©	45.7	MW
2	Annual Electric Energy Production (AEP)	120,000	MWeh/yr
	Therefore, Capacity Factor	29.95	%
3	Year Constant Dollars	2005	Year
4	Federal Tax Rate	35	%
5	State	Washington	
6	State Tax Rate	0	%
	Composite Tax Rate (t)	0.35	%
	t/(1-t)	0.5385	
7	Book Life	20	Years
8	Construction Financing Rate	9	
9	Common Equity Financing Share	30	%
10	Preferred Equity Financing Share	0	%
11	Debt Financing Share	70	%
12	Common Equity Financing Rate	17	%
13	Preferred Equity Financing Rate	0	%
14	Debt Financing Rate	8	%
	Current \$ Discount Rate Before-Tax	10.7	%
	Current \$ Discount Rate After-Tax	8.74	%
15	Inflation rate	3	%
16	Federal Investment Tax Credit	0	Assumed take PTC
17	Federal Production Tax Credit inc 3% escalation	0.018	\$/kWh for 1st 10 yrs
18	State Investment Tax Credit	0	
19	State Production Tax Credit	0	
20	Wholesale electricity price - 2005\$	0.0386	\$/kWh
21	Decline in wholesale elec. price from 2005 to 2008	4.20	%
22	Annual decline in wholesale price, 2009 - 2011	1.42	%
23	Annual increase in wholesale price, 2012 - 2025	0.72	%
24	Yearly Unscheduled O&M	5	% of Sch O&M cost
25	MACRS Year 1	0.2000	
26	MACRS Year 2	0.3200	
27	MACRS Year 3	0.1920	
28	MACRS Year 4	0.1152	
29	MACRS Year 5	0.1152	
30	MACRS Year 6	0.0576	
31	REC Rate	0.0000	\$/kWh for Project Life

Electricity Price Forecast Area

The electricity price forecast from the EIA (Doc 002, Reference 8):

"Average U.S. electricity prices, in real 2003 dollars, are expected to decline by 11% from 7.4 cents/kWh in 2003 to 6.6 cents in 2011, then rise to 7.3 cents/kWh in 2025."

	2003	7.4	7.4	
	2004		7.29	
Base	2005		7.19	
	2006		7.09	
	2007		6.99	
	2008		6.89	-4.20% Decline (2005 - 2008)
	2009		6.79	
	2010		6.7	
	2011	6.6	6.6	-1.42% Annual Decline (2009 - 2011)
	2012		6.65	
	2013		6.7	
	2014		6.74	
	2015		6.79	
	2016		6.84	
	2017		6.89	
	2018		6.94	
	2019		6.99	
	2020		7.04	
	2021		7.09	
	2022		7.14	
	2023		7.2	
	2024		7.25	
	2025	7.3	7.3	0.72% Annual Increase (2012 - 2025)

INCOME STATEMENT (\$)

CURRENT DOLLARS

Description/Year	2009	2010	2011	2012	2013	2014	2015	2016	2017
REVENUES									
Energy Payments	4,848,946	4,923,496	4,999,192	5,076,052	5,266,115	5,463,295	5,667,858	5,880,080	6,100,248
REC income	0	0	0	0	0	0	0	0	0
State ITC	0								
Federal ITC	0								
Federal PTC	2,160,000	2,224,800	2,291,544	2,360,290	2,431,099	2,504,032	2,579,153	2,656,528	2,736,223
TOTAL REVENUES	4,848,946	4,923,496	4,999,192	5,076,052	5,266,115	5,463,295	5,667,858	5,880,080	6,100,248
AVG \$/KWH	0.040	0.041	0.042	0.042	0.044	0.046	0.047	0.049	0.051
OPERATING COSTS									
Scheduled and Unscheduled O&M	3,812,000	3,926,360	4,044,151	4,165,475	4,290,439	4,419,153	4,551,727	4,688,279	4,828,927
Other	0	0	0	0	0	0	0	0	0
TOTAL	3,812,000	3,926,360	4,044,151	4,165,475	4,290,439	4,419,153	4,551,727	4,688,279	4,828,927
EBITDA	1,036,946	997,136	955,041	910,577	975,676	1,044,142	1,116,131	1,191,801	1,271,321
Tax Depreciation	21,192,651	33,908,241	20,344,945	12,206,967	12,206,967	0	0	0	0
Interest Paid	5,933,942	5,804,272	5,664,229	5,512,982	5,349,636	5,173,222	4,982,694	4,776,925	4,554,693
TAXABLE EARNINGS	-26,089,647	-38,715,378	-25,054,132	-16,809,372	-16,580,927	-4,129,079	-3,866,564	-3,585,124	-3,283,372
State Tax	0	0	0	0	0	0	0	0	0
Federal Tax	-9,131,376	-13,550,382	-8,768,946	-5,883,280	-5,803,324	-1,445,178	-1,353,297	-1,254,793	-1,149,180
TOTAL TAX OBLIGATIONS	-9,131,376	-13,550,382	-8,768,946	-5,883,280	-5,803,324	-1,445,178	-1,353,297	-1,254,793	-1,149,180

CURRENT DOLLARS

	2018	2019	2020	2021	2022	2023	2024	2025	2026	2027	2028
	6,328,661	6,565,625	6,811,463	7,066,505	7,331,097	7,605,596	7,890,373	8,185,813	8,492,316	8,810,294	9,140,179
	0	0	0	0	0	0	0	0	0	0	0
	2,818,310										
	6,328,661	6,565,625	6,811,463	7,066,505	7,331,097	7,605,596	7,890,373	8,185,813	8,492,316	8,810,294	9,140,179
	0.053	0.055	0.057	0.059	0.061	0.063	0.066	0.068	0.071	0.073	0.076
	4,973,795	5,123,009	5,276,699	5,435,000	5,598,050	5,765,992	5,938,971	6,117,141	6,300,655	6,489,674	6,684,365
	0	0	0	0	0	0	0	0	0	0	0
	4,973,795	5,123,009	5,276,699	5,435,000	5,598,050	5,765,992	5,938,971	6,117,141	6,300,655	6,489,674	6,684,365
	1,354,865	1,442,616	1,534,764	1,631,505	1,733,047	1,839,604	1,951,402	2,068,673	2,191,661	2,320,620	2,455,815
	0	0	0	0	0	0	0	0	0	0	0
	4,314,684	4,055,473	3,775,526	3,473,183	3,146,653	2,794,000	2,413,135	2,001,800	1,557,559	1,077,779	559,616
	-2,959,818	-2,612,857	-2,240,763	-1,841,678	-1,413,606	-954,395	-461,733	66,873	634,102	1,242,841	1,896,199
	0	0	0	0	0	0	0	0	0	0	0
	-1,035,936	-914,500	-784,267	-644,587	-494,762	-334,038	-161,606	23,405	221,936	434,994	663,670
	-1,035,936	-914,500	-784,267	-644,587	-494,762	-334,038	-161,606	23,405	221,936	434,994	663,670

CASH FLOW STATEMENT

<u>Description/Year</u>	2007	2008	2009	2010	2011	2012
EBITDA			1,036,946	997,136	955,041	910,577
Taxes Paid			-9,131,376	-13,550,382	-8,768,946	-5,883,280
CASH FLOW FROM OPS			10,168,322	14,547,518	9,723,988	6,793,857
Debt Service			-7,554,814	-7,554,814	-7,554,814	-7,554,814
NET CASH FLOW AFTER TAX		-31,788,976	2,613,508	6,992,704	2,169,174	-760,957
CUM NET CASH FLOW		-31,788,976	-29,175,468	-22,182,764	-20,013,590	-20,774,547

IRR ON NET CASH FLOW AFTER TAX

CASH FLOW STATEMENT

2013	2014	2015	2016	2017	2018	2019	2020	2021
975,676	1,044,142	1,116,131	1,191,801	1,271,321	1,354,865	1,442,616	1,534,764	1,631,505
-5,803,324	-1,445,178	-1,353,297	-1,254,793	-1,149,180	-1,035,936	-914,500	-784,267	-644,587
6,779,000	2,489,320	2,469,428	2,446,594	2,420,501	2,390,802	2,357,116	2,319,030	2,276,092
-7,554,814	-7,554,814	-7,554,814	-7,554,814	-7,554,814	-7,554,814	-7,554,814	-7,554,814	-7,554,814
-775,814	-5,065,494	-5,085,386	-5,108,220	-5,134,313	-5,164,012	-5,197,698	-5,235,784	-5,278,722
-21,550,361	-26,615,854	-31,701,241	-36,809,460	-41,943,773	-47,107,785	-52,305,483	-57,541,266	-62,819,988

2022	2023	2024	2025	2026	2027	2028
1,733,047	1,839,604	1,951,402	2,068,673	2,191,661	2,320,620	2,455,815
-494,762	-334,038	-161,606	23,405	221,936	434,994	663,670
2,227,809	2,173,643	2,113,008	2,045,267	1,969,725	1,885,626	1,792,145
-7,554,814	-7,554,814	-7,554,814	-7,554,814	-7,554,814	-7,554,814	-7,554,814
-5,327,005	-5,381,171	-5,441,806	-5,509,547	-5,585,089	-5,669,188	-5,762,669
-68,146,993	-73,528,164	-78,969,970	-84,479,517	-90,064,605	-95,733,794	-101,496,463

IRR ON NET CASH FLOW AFTER TAX

#DIV/0!

12.6. Municipal Utility Generator Cost of Electricity Worksheet

INSTRUCTIONS					
		Indicates Input Cell (either input or use default values)			
		Indicates a Calculated Cell (do not input any values)			
Sheet 1. TPC/TPI (Total Plant Cost/Total Plant Investment)					
	a)	Enter Component Unit Cost and No. of Units per System			
	b)	Worksheet sums component costs to get TPC			
	c)	Adds the value of the construction loan payments to get TPI			
	a)	Enter Labor Hrs and and Parts Cost by O&M inc overhaul and refit			
	c)	Worksheet Calculates Insurance and Total Annual O&M Cost			
Sheet 3. O&R (Overhaul and Replacement Cost)					
	a)	Enter Year of Cost and O&R Cost per Item			
	b)	Worksheets calculates the present value of the O&R costs			
Sheet 4. Assumptions (Financial)					
	a)	Enter project and financial assumptions or leave default values			
Sheet 5. NPV (Net Present Value)					
	A	Gross Book Value = TPI			
	B	Annual Book Depreciation = Gross Book Value/Book Life			
	C	Cumulative Depreciation			
	D	MACRS 5 Year Depreciation Tax Schedule Assumption			
	E	Deferred Taxes = (Gross Book Value X MACRS Rate - Annual Book Depreciation) X Debt Financing Rate			
	F	Net Book Value = Previous Year Net Book Value - Annual Book Depreciation - Deferred Tax for that Year			
Sheet 6. CRR (Capital Revenue Requirements)					
	A	Net Book Value for Column F of NPV Worksheet			
	B	Common Equity = Net Book X Common Equity Financing Share X Common Equity Financing Rate			
	C	Preferred Equity = Net Book X Preferred Equity Financing Share X Preferred Equity Financing Rate			
	D	Debt = Net Book X Debt Financing Share X Debt Financing Rate			
	E	Annual Book Depreciation = Gross Book Value/Book Life			
	F	Income Taxes = (Return on Common Equity + Return of Preferred Equity + Interest on Debt + Deferred Taxes) X (Comp Tax Rate / (1 - Comp Tax Rate))			
	G	Property Taxes and Insurance Expense =			
	H	Calculates Investment and Production Tax Credit Revenues			
	I	Capital Revenue Req'ts = Sum of Columns B through G			
Sheet 7. FCR (Fixed Charge Rate)					
	A	Nominal Rates Capital Revenue Req'ts from Columnn H of Previous Worksheet			
	B	Nominal Rate Present Worth Factor = 1 / (1 + After Tax Discount Rate)			
	C	Nominal Rate Product of Columns A and B = A * B			
	D	Real Rates Capital Revenue Req'ts from Columnn H of Previous Worksheet			
	E	Real Rates Present Worth Factor = 1 / (1 + After Tax Discount Rate - Inflation Rate)			
	F	Real Rates Product of Columns A and B = A * B			
Sheet 8. Calculates COE (Cost of Electricity)					
		COE = ((TPI * FCR) + AO&M + LO&R) / AEP			
		In other words...The Cost of Electricity =			
		The Sum of the Levelized Plant Investment + Annual O&M Cost including Levelized Overhaul and Replacement Cost Divided by the Annual Electric Energy Consumption			

TOTAL PLANT COST (TPC) - 2005\$

TPC Component	Unit	Unit Cost	Total Cost (2005\$)
Procurement			
Power Conversion System	64	\$472,665	\$30,250,532
Structural Elements	64	\$605,062	\$38,723,977
Subsea Cables	Lot	\$812,705	\$812,705
Turbine Installation	64	\$322,406	\$20,633,956
Subsea Cable Installation	Lot	\$9,541,969	\$9,541,969
Onshore Grid Interconnection	Lot	\$3,500,000	\$3,500,000
TOTAL			\$103,463,138

TOTAL PLANT INVESTMENT (TPI) - 2005\$

End of Year	Total Cash Expended TPC (2005\$)	Before Tax Construction Loan Cost at Debt Financing Rate	2005 Value of Construction Loan Payments	TOTAL PLANT INVESTMENT 2005\$
2007	\$51,731,569	\$2,586,578	\$2,346,103	\$54,077,672
2008	\$51,731,569	\$2,586,578	\$2,234,384	\$53,965,953
Total	\$103,463,138	\$5,173,157	\$4,580,487	\$108,043,625

ANNUAL OPERATING AND MAINTENANCE COST (AO&M) - 2005\$

Costs	Yrly Cost	Amount
Labor and Parts	\$2,260,052	\$2,260,052
Insurance (1.5% of TPC)	\$1,551,947	\$1,551,947
Total		\$3,811,999

FINANCIAL ASSUMPTIONS**(default assumptions in pink background - without line numbers are calculated values)**

	Rated Plant Capacity ©	45.81772391	MW
	Annual Electric Energy Production (AEP)	120,007	MWeh/yr
	Therefore, Capacity Factor	29.9	%
1	Year Constant Dollars	2005	Year
2	Construction Start	2007	Year
3	Construction Period	2	Year
	Federal Tax Rate	-	%
5	State	Washington ▼	
6	Generator	Municipal Generator ▼	
	State Tax Rate	-	%
	Composite Tax Rate (t)	0.00000	
	t/(1-t)	0.00000	
7	Book Life	20	Years
	Construction Financing Rate	5.0	%
	Common Equity Financing Share	-	%
	Preferred Equity Financing Share	-	%
	Debt Financing Share	100	%
	Common Equity Financing Rate	-	%
	Preferred Equity Financing Rate	-	%
	Debt Financing Rate	5.0	%
	Nominal Discount Rate Before-Tax	5	%
	Nominal Discount Rate After-Tax	5.00	%
8	Inflation Rate = 3%	3	%
	Real Discount Rate Before-Tax	1.94	%
	Real Discount Rate After-Tax	1.94	%
	Federal Investment Tax Credit (1)	0	
	Federal Production Tax Credit (2)	0.000	
	Federal REPI (3)	0.015	
	State Investment Tax Credit	0	\$
	State Investment Tax Credit Limit	None	
	Renewable Energy Certificate (4)	0.000	\$/kWh

Notes

- 1 1st year only - cannot take Fed ITC and PTC
- 2 \$/kWh for 1st 10 years with escalation (assumed 3% per yr)
- 3 \$/kWh for 1st 10 years with escalation (assumed 3% per yr)
- 4 \$/kWh for entire plant life with escalation (assumed 3% per yr)

NET PRESENT VALUE (NPV) - 2005 \$

TPI = **\$108,043,625**

Year End	Gross Book Value A	Book Depreciation		Renewable Resource MACRS Tax Depreciation Schedule D	Deferred Taxes E	Net Book Value F
		Annual B	Accumulated C			
2008	108,043,625					108,043,625
2009	108,043,625	5,402,181	5,402,181	0.2000	0	102,641,444
2010	108,043,625	5,402,181	10,804,363	0.3200	0	97,239,263
2011	108,043,625	5,402,181	16,206,544	0.1920	0	91,837,081
2012	108,043,625	5,402,181	21,608,725	0.1152	0	86,434,900
2013	108,043,625	5,402,181	27,010,906	0.1152	0	81,032,719
2014	108,043,625	5,402,181	32,413,088	0.0576	0	75,630,538
2015	108,043,625	5,402,181	37,815,269	0.0000	0	70,228,356
2016	108,043,625	5,402,181	43,217,450	0.0000	0	64,826,175
2017	108,043,625	5,402,181	48,619,631	0.0000	0	59,423,994
2018	108,043,625	5,402,181	54,021,813	0.0000	0	54,021,813
2019	108,043,625	5,402,181	59,423,994	0.0000	0	48,619,631
2020	108,043,625	5,402,181	64,826,175	0.0000	0	43,217,450
2021	108,043,625	5,402,181	70,228,356	0.0000	0	37,815,269
2022	108,043,625	5,402,181	75,630,538	0.0000	0	32,413,088
2023	108,043,625	5,402,181	81,032,719	0.0000	0	27,010,906
2024	108,043,625	5,402,181	86,434,900	0.0000	0	21,608,725
2025	108,043,625	5,402,181	91,837,081	0.0000	0	16,206,544
2026	108,043,625	5,402,181	97,239,263	0.0000	0	10,804,363
2027	108,043,625	5,402,181	102,641,444	0.0000	0	5,402,181
2028	108,043,625	5,402,181	108,043,625	0.0000	0	0

CAPITAL REVENUE REQUIREMENTS 2005\$

TPI = \$108,043,625

End of Year	Net Book	Returns to Equity Common	Returns to Equity Pref	Interest on Debt	Book Dep	Income Tax on Equity Return	Fed PTC and REC	Capital Revenue Req'ts
	A	B	C	D	E	F	H	I
2009	102,641,444	0	0	5,132,072	5,402,181	0	1,800,105	8,734,148
2010	97,239,263	0	0	4,861,963	5,402,181	0	1,800,105	8,464,039
2011	91,837,081	0	0	4,591,854	5,402,181	0	1,800,105	8,193,930
2012	86,434,900	0	0	4,321,745	5,402,181	0	1,800,105	7,923,821
2013	81,032,719	0	0	4,051,636	5,402,181	0	1,800,105	7,653,712
2014	75,630,538	0	0	3,781,527	5,402,181	0	1,800,105	7,383,603
2015	70,228,356	0	0	3,511,418	5,402,181	0	1,800,105	7,113,494
2016	64,826,175	0	0	3,241,309	5,402,181	0	1,800,105	6,843,385
2017	59,423,994	0	0	2,971,200	5,402,181	0	1,800,105	6,573,276
2018	54,021,813	0	0	2,701,091	5,402,181	0	1,800,105	6,303,167
2019	48,619,631	0	0	2,430,982	5,402,181	0	0	7,833,163
2020	43,217,450	0	0	2,160,873	5,402,181	0	0	7,563,054
2021	37,815,269	0	0	1,890,763	5,402,181	0	0	7,292,945
2022	32,413,088	0	0	1,620,654	5,402,181	0	0	7,022,836
2023	27,010,906	0	0	1,350,545	5,402,181	0	0	6,752,727
2024	21,608,725	0	0	1,080,436	5,402,181	0	0	6,482,618
2025	16,206,544	0	0	810,327	5,402,181	0	0	6,212,508
2026	10,804,363	0	0	540,218	5,402,181	0	0	5,942,399
2027	5,402,181	0	0	270,109	5,402,181	0	0	5,672,290
2028	0	0	0	0	5,402,181	0	0	5,402,181
Sum of Annual Capital Revenue Requirements								141,363,295

FIXED CHARGE RATE (FCR) - NOMINAL AND REAL LEVELIZED - 2005\$

TPI = \$108,043,625

End of Year	Capital Revenue Req'ts Nominal A	Present Worth Factor Nominal B	Product of Columns A and B C	Capital Revenue Req'ts Real D	Present Worth Factor Real E	Product of Columns D and E F
2009	8,734,148	0.8227	7,185,605	7,760,178	0.9260	7,185,605
2010	8,464,039	0.7835	6,631,796	7,301,155	0.9083	6,631,796
2011	8,193,930	0.7462	6,114,437	6,862,287	0.8910	6,114,437
2012	7,923,821	0.7107	5,631,312	6,442,792	0.8740	5,631,312
2013	7,653,712	0.6768	5,180,334	6,041,911	0.8574	5,180,334
2014	7,383,603	0.6446	4,759,536	5,658,917	0.8411	4,759,536
2015	7,113,494	0.6139	4,367,068	5,293,107	0.8250	4,367,068
2016	6,843,385	0.5847	4,001,185	4,943,807	0.8093	4,001,185
2017	6,573,276	0.5568	3,660,246	4,610,363	0.7939	3,660,246
2018	6,303,167	0.5303	3,342,704	4,292,150	0.7788	3,342,704
2019	7,833,163	0.5051	3,956,280	5,178,643	0.7640	3,956,280
2020	7,563,054	0.4810	3,637,958	4,854,436	0.7494	3,637,958
2021	7,292,945	0.4581	3,340,982	4,544,722	0.7351	3,340,982
2022	7,022,836	0.4363	3,064,040	4,248,931	0.7211	3,064,040
2023	6,752,727	0.4155	2,805,897	3,966,515	0.7074	2,805,897
2024	6,482,618	0.3957	2,565,392	3,696,946	0.6939	2,565,392
2025	6,212,508	0.3769	2,341,429	3,439,715	0.6807	2,341,429
2026	5,942,399	0.3589	2,132,979	3,194,332	0.6677	2,132,979
2027	5,672,290	0.3418	1,939,072	2,960,326	0.6550	1,939,072
2028	5,402,181	0.3256	1,758,795	2,737,241	0.6425	1,758,795
	141,363,295		78,417,047	98,028,475		78,417,047

	Nominal \$	Real \$
1. The present value is at the beginning of 2006 and results from the sum of the products of the annual present value factors times the annual requirements	78,417,047	78,417,047
2. Escalation Rate	3%	3%
3. After Tax Discount Rate = i	5.00%	1.94%
4. Capital recovery factor value = $i(1+i)^n / (1+i)^n - 1$ where book life = n and discount rate = i	0.080242587	0.060813464
5. The levelized annual charges (end of year) = Present Value (Item 1) * Capital Recovery Factor (Item 4)	6,292,387	4,768,812
6. Booked Cost	108,043,625	108,043,625
7. The levelized annual fixed charge rate (levelized annual charges divided by the booked cost)	0.0582	0.0441

LEVELIZED COST OF ELECTRICITY CALCULATION - Municipal Generator - 2005\$

$COE = ((TPI * FCR) + AO\&M) / AEP$

In other words...

The Cost of Electricity =

The Sum of the Levelized Plant Investment + Annual O&M Cost including Levelized Overhaul and Replacement Cost
Divided by the Annual Electric Energy Consumption

NOMINAL RATES

	<u>Value</u>	<u>Units</u>	<u>From</u>
TPI	\$108,043,625	\$	From TPI
FCR	5.82%	%	From FCR
AO&M	\$3,811,999	\$	From AO&M
AEP =	120,007	MWeh/yr	From Assumptions
COE - TPI X FCR	5.24	cents/kWh	
COE - AO&M	3.18	cents/kWh	
COE	\$0.0842	\$/kWh	Calculated
COE	8.42	cents/kWh	Calculated

REAL RATES

TPI	\$108,043,625	\$	From TPI
FCR	4.41%	%	From FCR
AO&M	\$3,811,999	\$	From AO&M
AEP =	120,007	MWeh/yr	From Assumptions
COE - TPI X FCR	3.97	cents/kWh	
COE - AO&M	3.18	cents/kWh	
COE	\$0.0715	\$/kWh	Calculated
COE	7.15	cents/kWh	Calculated